

**PHILIPS**

Data handbook



Electronic  
components  
and materials

**Components and  
materials**

Book C17

1986

**Stepping motors and  
associated electronics**



# STEPPING MOTORS AND ASSOCIATED ELECTRONICS

	<i>page</i>
<i>Preface</i>	ii
<b>Stepping motors, General</b>	
Survey of types . . . . .	2
Introduction . . . . .	3
Principles . . . . .	4
Practical aspects. . . . .	10
Typical motor calculation . . . . .	19
Terminology . . . . .	24
Additional information to motor specifications . . . . .	26
4-phase unipolar motors . . . . .	27
2-phase bipolar motors . . . . .	30
4-phase bipolar motors . . . . .	31
<b>Device specifications . . . . .</b>	<b>32</b>
<b>Associated electronics</b>	
Integrated circuit for 4-phase unipolar stepping motors . . . . .	135
Electronic drive unit, 4-phase unipolar . . . . .	139
Electronic drive unit, 2-phase bipolar . . . . .	143
Electronic drive unit, 4-phase bipolar . . . . .	147
<b>Index of catalogue numbers. . . . .</b>	<b>151</b>

## PREFACE

New materials and manufacturing methods have enabled us to introduce motors to our range that have considerably improved characteristics and are at the same time less expensive. Some replace types that are widely used by many customers and, for this reason, are identical in fit and function to those they replace but with advantages in characteristics and price.

### Notes

All mechanical drawings are in accordance with the European (third angle) projection.

Dimensions are given in mm.

Forces are given in newtons (N);  $1 \text{ N} = 100 \text{ g} = 3,53 \text{ ounce (oz)}$ .

Torques are given in milli-newton-metres (mNm);  $1 \text{ mNm} = 10 \text{ gcm} = 0,139 \text{ ounce inch}$ .

Performance curves are derived from measurements made on typical motors.

The sense of rotation, clockwise (cw) or counterclockwise (ccw), is as viewed from the spindle end of the motor.

When ordering, please use the catalogue number.



## DATA HANDBOOK SYSTEM

Our Data Handbook System comprises more than 60 books with specifications on electronic components, subassemblies and materials. It is made up of four series of handbooks:

ELECTRON TUBES	BLUE
SEMICONDUCTORS	RED
INTEGRATED CIRCUITS	PURPLE
COMPONENTS AND MATERIALS	GREEN

The contents of each series are listed on pages iv to viii.

The data handbooks contain all pertinent data available at the time of publication, and each is revised and reissued periodically.

When ratings or specifications differ from those published in the preceding edition they are indicated with arrows in the page margin. Where application information is given it is advisory and does not form part of the product specification.

Condensed data on the preferred products of Philips Electronic Components and Materials Division is given in our Preferred Type Range catalogue (issued annually).

Information on current Data Handbooks and on how to obtain a subscription for future issues is available from any of the Organizations listed on the back cover.

Product specialists are at your service and enquiries will be answered promptly.

## ELECTRON TUBES (BLUE SERIES)

The blue series of data handbooks comprises:

- T1** Tubes for r.f. heating
- T2a** Transmitting tubes for communications, glass types
- T2b** Transmitting tubes for communications, ceramic types
- T3** Klystrons
- T4** Magnetrons for microwave heating
- T5** Cathode-ray tubes  
Instrument tubes, monitor and display tubes, C.R. tubes for special applications
- T6** Geiger-Müller tubes
- T8** Colour display systems  
Colour TV picture tubes, colour data graphic display tube assemblies, deflection units
- T9** Photo and electron multipliers
- T10** Plumbicon camera tubes and accessories
- T11** Microwave semiconductors and components
- T12** Vidicon and Newvicon camera tubes
- T13** Image intensifiers and infrared detectors
- T15** Dry reed switches
- T16** Monochrome tubes and deflection units  
Black and white TV picture tubes, monochrome data graphic display tubes, deflection units

## SEMICONDUCTORS (RED SERIES)

The red series of data handbooks comprises:

- S1 Diodes**  
Small-signal silicon diodes, voltage regulator diodes (< 1,5 W), voltage reference diodes, tuner diodes, rectifier diodes
- S2a Power diodes**
- S2b Thyristors and triacs**
- S3 Small-signal transistors**
- S4a Low-frequency power transistors and hybrid modules**
- S4b High-voltage and switching power transistors**
- S5 Field-effect transistors**
- S6 R.F. power transistors and modules**
- S7 Surface mounted semiconductors**
- S8a Light-emitting diodes**
- S8b Devices for optoelectronics**  
Optocouplers, photosensitive diodes and transistors, infrared light-emitting diodes and infrared sensitive devices, laser and fibre-optic components
- S9 Power MOS transistors**
- S10 Wideband transistors and wideband hybrid IC modules**
- S11 Microwave transistors**
- S12 Surface acoustic wave devices**
- S13 Semiconductor sensors**

## INTEGRATED CIRCUITS (PURPLE SERIES)

The purple series of data handbooks comprises:

### EXISTING SERIES

Superseded by:

<b>IC1</b>	<b>Bipolar ICs for radio and audio equipment</b>	<b>IC01N</b>
<b>IC2</b>	<b>Bipolar ICs for video equipment</b>	<b>IC02Na and IC02Nb</b>
<b>IC3</b>	<b>ICs for digital systems in radio, audio and video equipment</b>	<b>IC01N, IC02Na and IC02Nb</b>
<b>IC4</b>	<b>Digital integrated circuits</b> CMOS HE4000B family	
<b>IC5</b>	<b>Digital integrated circuits – ECL</b> ECL10 000 (GX family), ECL100 000 (HX family), dedicated designs	<b>IC08N</b>
<b>IC6</b>	<b>Professional analogue integrated circuits</b>	<b>IC03N and Supplement to IC11N</b>
<b>IC7</b>	<b>Signetics bipolar memories</b>	
<b>IC8</b>	<b>Signetics analogue circuits</b>	<b>IC11N</b>
<b>IC9</b>	<b>Signetics TTL logic</b>	<b>IC09N and IC15N</b>
<b>IC10</b>	<b>Signetics Integrated Fuse Logic (IFL)</b>	<b>IC13N</b>
<b>IC11</b>	<b>Microprocessors, microcomputers and peripheral circuitry</b>	<b>IC14N</b>

## NEW SERIES

<b>IC01N</b>	<b>Radio, audio and associated systems</b> Bipolar, MOS	(published 1985)
<b>IC02Na</b>	<b>Video and associated systems</b> Bipolar, MOS Types MAB8031AH to TDA1524A	(published 1985)
<b>IC02Nb</b>	<b>Video and associated systems</b> Bipolar, MOS Types TDA2501 to TEA1002	(published 1985)
<b>IC03N</b>	<b>Integrated circuits for telephony</b>	(published 1985)
<b>IC04N</b>	<b>HE4000B logic family</b> CMOS	
<b>IC05N</b>	<b>HE4000B logic family – incased ICs</b> CMOS	(published 1984)
<b>IC06N*</b>	<b>High-speed CMOS; PC74HC/HCT/HCU</b> Logic family	(published 1986)
<b>IC07N</b>	<b>High-speed CMOS; PC54/74HC/HCT/HCU – uncased ICs</b> Logic family	
<b>IC08N</b>	<b>ECL 10K and 100K logic families</b>	(published 1984)
<b>IC09N</b>	<b>TTL logic series</b>	(published 1986)
<b>IC10N</b>	<b>Memories</b> MOS, TTL, ECL	
<b>IC11N</b>	<b>Linear LSI</b>	(published 1985)
<b>Supplement to IC11N</b>	<b>Linear LSI</b>	(published 1986)
<b>IC12N</b>	<b>Semi-custom gate arrays &amp; cell libraries</b> ISL, ECL, CMOS	
<b>IC13N</b>	<b>Semi-custom</b> Integrated Fuse Logic	(published 1985)
<b>IC14N</b>	<b>Microprocessors, microcontrollers &amp; peripherals</b> Bipolar, MOS	(published 1985)
<b>IC15N</b>	<b>FAST TTL logic series</b>	(published 1984)

### Note

Books available in the new series are shown with their date of publication.

\* Supersedes the IC06N 1985 edition and the Supplement to IC06N issued Autumn 1985.

## COMPONENTS AND MATERIALS (GREEN SERIES)

The green series of data handbooks comprises:

- C1 Programmable controller modules**  
PLC modules, PC20 modules
- C2 Television tuners, coaxial aerial input assemblies, surface acoustic wave filters**
- C3 Loudspeakers**
- C4 Ferroxcube potcores, square cores and cross cores**
- C5 Ferroxcube for power, audio/video and accelerators**
- C6 Synchronous motors and gearboxes**
- C7 Variable capacitors**
- C8 Variable mains transformers**
- C9 Piezoelectric quartz devices**
- C10 Connectors**
- C11 Non-linear resistors**
- C12 Potentiometers, encoders and switches**
- C13 Fixed resistors**
- C14 Electrolytic and solid capacitors**
- C15 Ceramic capacitors**
- C16 Permanent magnet materials**
- C17 Stepping motors and associated electronics**
- C18 Direct current motors**
- C19 Piezoelectric ceramics**
- C20 Wire-wound components for TVs and monitors**
- C21\* Assemblies for industrial use**  
HNIL FZ/30 series, NORbits 60-, 61-, 90-series, input devices
- C22 Film capacitors**

\* To be issued shortly

## STEPPING MOTORS

## SURVEY OF TYPES

series	step angle degrees	holding torque mNm	catalogue number	page
<b>PERMANENT MAGNET STEPPING MOTORS</b>				
<b>4-phase unipolar motors</b>				
ID06	7,5°	70	9904 112 06001	33
	7,5°	70	06101	33
ID27	7,5°	140	27001	37
	7,5°	150	27101	37
ID28	15°	80	28001	45
	15°	85	28101	45
ID31	7,5°	30	31001	59
	7,5°	34	31101	59
ID31E	7,5°	28	31004	63
	7,5°	32	31104	63
ID31E	7,5°	42	31006	67
	7,5°	46	31106	67
ID32	7,5°	10	32001	75
	7,5°	10	32101	75
ID33E	7,5°	130	33004	83
	7,5°	130	33104	83
ID33	7,5°	150	33105	87
ID34E	15°	75	34004	91
	15°	80	34104	91
ID35E	7,5°	85	35014	95
	7,5°	85	35114	95
	7,5°	85	35016	99
	7,5°	95	35116	99
ID36E	15°	60	36014	111
	15°	60	36114	111
<b>2-phase bipolar motors</b>				
ID27B	7,5°	170	9904 112 27201	41
ID28B	15°	110	28201	49
ID31BE	7,5°	55	31206	71
ID32BE	7,5°	11,5	32204	79
ID35BE	7,5°	90	35214	103
	7,5°	125	35216	107
<b>4-phase bipolar motors</b>				
ID29B	3,75°	300	9904 112 29201	52
ID30B	7,5°	210	30201	55
<b>HYBRID STEPPING MOTORS</b>				
HR15	1,8°	55	9904 115 15101	115
	1,8°	60	15201	119
	1,8°	60	15401	123
HR23	1,8°	450	23 . . .	127



## INTRODUCTION

A stepping motor converts digital information into proportional mechanical movement; it is an electro-mechanical device whose spindle rotates in discrete steps, following command pulses in number and speed, when operated from a source that provides programmed current reversals.

After the appearance of the stepping motor in applications traditionally employing digital control, the advantages of precise and rapid positioning of objects using electronics became more obvious and this, in turn, led to a greater variety of applications. These now include:

- paper and magnetic tape drives;
- teletype and strip printers;
- camera iris control, film transport and colour film sorting;
- co-ordinate plotters, incremental chart recorders and variable speed chart drives;
- medical equipment, e.g. blood samplers, lung analysers and kidney pumps;
- fuel flow control, valve control and variable speed syringe pumps;
- taxi-meters, card readers, production line pulse counters, and automatic weighing and labelling systems;
- digital-to-analogue converters and remote position indicating equipment.

All have one thing in common – controlled motion. Wherever controlled movement and/or positioning is necessary, the stepping motor can be applied. And usually to advantage.

From a mechanical viewpoint, the stepping motor has simple positional control, reliability and precision – it has, however, introduced the need for electronics. Where previously, simple, mechanically operated switches often provided adequate control, the need for a better method has arisen. The advantages of stepping motor systems have been gained at some expense to the simplicity of the motor control: although still unsophisticated by modern standards, some electronic circuits are necessary.

The full benefit of a stepping motor can only be realized if it is correctly driven. It requires a d.c. supply, an electronic switch and a source of control pulses (digital information). The appropriate d.c. supply is routed to the motor via the electronic switch. In effect, the motor moves through one step for each control pulse applied to the electronic switch. The angle of the step depends upon the type of motor and can be from as little as  $1,8^{\circ}$  to as much as  $15^{\circ}$ . Consequently, if 24 pulses are fed to the switch, the shaft of a motor with a  $15^{\circ}$  step-angle will complete one revolution. The time taken for this action is entirely a function of the rate at which control pulses are applied. These may be generated by an oscillator with adjustable frequency, or derived from one of a variety of sources: perforated tape, magnetic tape, etc.

## PRINCIPLES

The range of stepping motors comprises:

- permanent magnet versions
- hybrid versions

### PERMANENT MAGNET STEPPING MOTORS

The step angle of a permanent magnet stepping motor depends upon the relationship between the number of magnetic poles on its stator assembly and the number of magnetic poles on its rotor. Since the latter is a cylindrical permanent magnet, the poles are fixed, and their number is limited, due to the characteristics of the magnetic material. Enlarging the magnet diameter to provide for a larger number of rotor poles results in a drastic increase in the rotor inertia. This reduces the starting capabilities of such a motor beyond practical use. With a permanent magnet rotor, only relatively large step angles can be obtained. However, further reduction of the step angle can be achieved by using more stators. This enables step angles down to  $3,75^\circ$  to be obtained.

The stator assembly comprises two or more stators, each having a coil through which current is passed to form a magnetic field. By reversing the direction of current flowing in a coil, therefore, the north and south poles can be transposed. Reversing the current-flow through successive stator coils creates a rotating magnetic field which the permanent-magnet rotor follows. Speed of rotation is thus governed by the rate at which the stator coils (and hence the electro-magnetic poles) are switched and the direction of rotation by the actual switching sequence.

There are two methods by which the current-flow through stator coils can be reversed and this has led to two classes of stepping motor: those designed for unipolar drive and those for bipolar drive.

For ease of description, illustrations in this section which give a diagrammatic representation of a permanent magnet stepping motor show only a 2-pole rotor although it could have as many as 24: the operating principles, however, are the same.

#### Motors for Unipolar drive

Each stator coil of a motor designed for unipolar drive is provided with a centre-tap which is connected to one side of the supply, say, the positive. The direction of current flowing through a coil is then determined by the end to which the negative supply line is connected via a switching device. Switching coil-halves results in the magnetic poles of the relevant stator being reversed.

#### *2-STATOR MOTORS (4-PHASE)*

Fig. 1a shows a 4-phase stepping motor in which phases P and R are energized: the rotor assumes the position indicated. If switch S1 is now operated (phases Q and R energized), the conditions illustrated in Fig. 1b obtain, i.e. the rotor has moved through 90 degrees. From this it can be seen that by operating switches S1 and S2 alternately, the rotor can be made to rotate in  $90^\circ$  steps. The direction of rotation can be reversed by altering the switching sequence.

#### Motors for Bipolar drive

The stator coils of a motor designed for bipolar drive have no centre-tap. Instead of using alternate coil-halves to produce a reversal of current-flow through the stator windings (as for unipolar drive), the current is now reversed through the entire coil by switching both supply lines. Operation of a motor with bipolar drive is identical to that of one with unipolar drive.

#### *2-STATOR MOTORS (2-PHASE)*

Operation of a 2-phase motor with bipolar drive is shown in Fig. 2.

#### *4-STATOR MOTORS (4-PHASE)*

The 4-phase motor with bipolar drive is shown in Fig. 3.

UNIPOLAR OPERATION

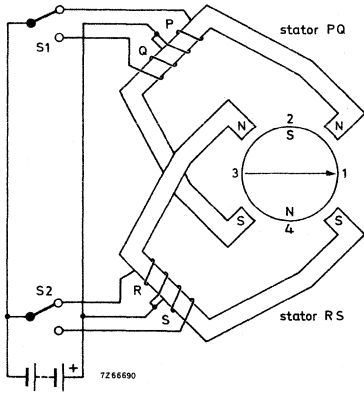

Fig. 1a. Two stator motors (4-phase).

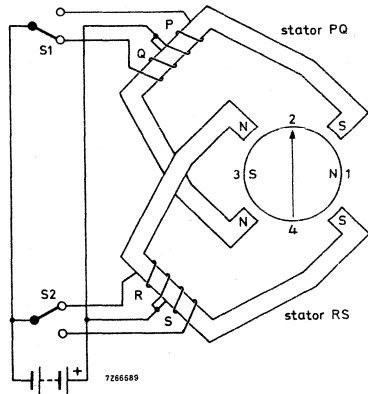

Fig. 1b.

BIPOLAR OPERATION

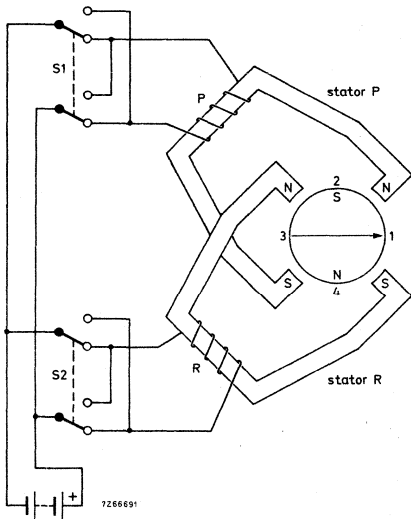

Fig. 2a. Two stator motors (2-phase).

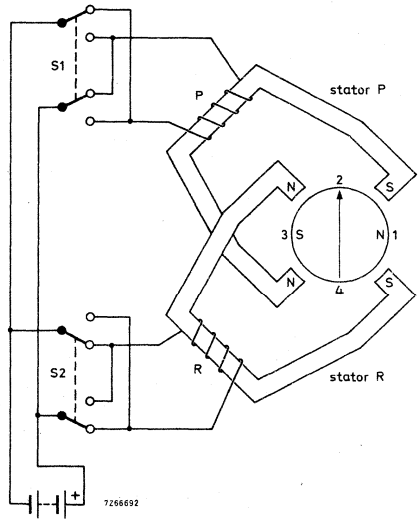

Fig. 2b.

GENERAL

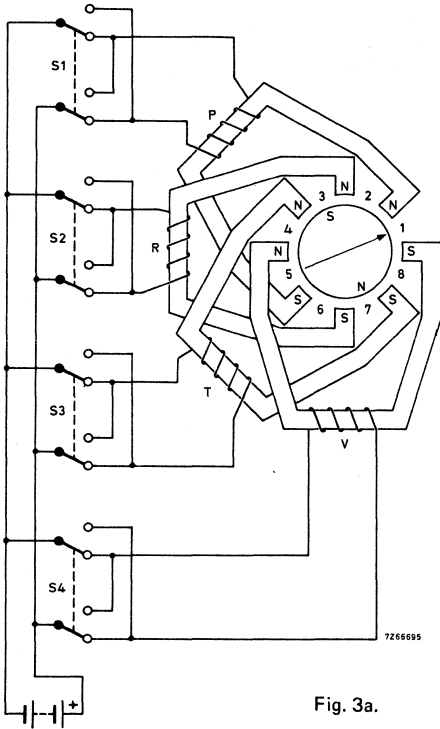

Fig. 3a.

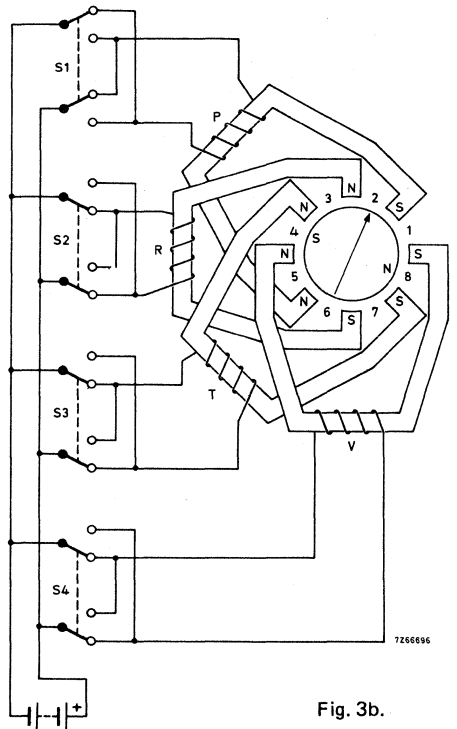

Fig. 3b.

Fig. 3 Four stator motors (4-phase).

### Features of the bipolar drive

The advantages of using motors with bipolar drive are shown in Fig. 4. This compares the performance of one of the unipolar motors with its bipolar version. A considerable increase in available torque is apparent using the bipolar version: the associated electronics, however, are necessarily somewhat more complex.

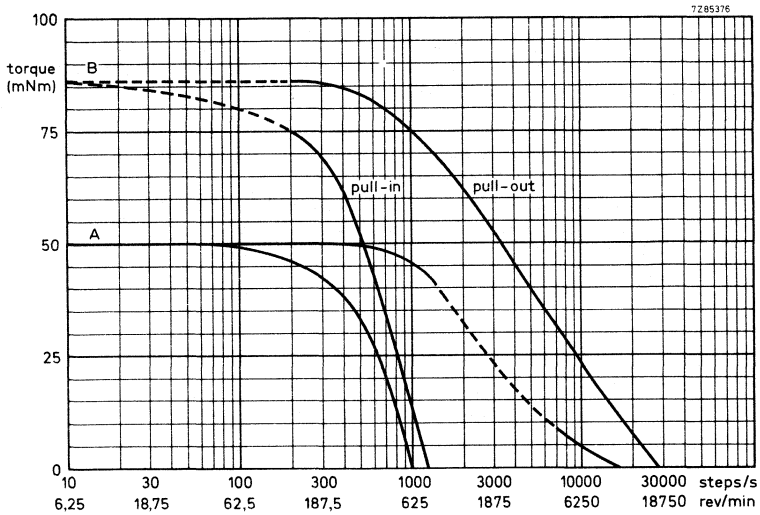

Fig. 4.  
A: unipolar motor;  
B: bipolar motor.

HYBRID STEPPING MOTORS

Our hybrid stepping motor technology is based upon a principle which gives options in step angle and motor size beyond those possible with the common design of hybrid stepping motors. This new design consists of four stator cups assembled face to face around a ring coil thus, forming two closed stator parts joined by a permanent magnet. The inner circumference of each stator cup has teeth, the number of teeth depending on the step angle required. The rotor consists of four discs, with the same number of teeth as the stator cups. The rotor discs are offset from each other by half a tooth-pitch in a pattern dictated by the necessary energizing sequence of the ring coils. The teeth of the stator cups are in line. The permanent magnet flux is distributed through each stator part and closed via the rotor. When the stator coils are energized alternately and in both directions a rotating magnetic field is produced which the rotor follows. At each step in the energizing sequence, the teeth of one rotor disc line-up with the teeth of the stator cups.

Fig. 5 shows the basic design of this 4-phase motor. For simplicity, one tooth per rotor disc and stator cup is shown giving a step angle of 90 degrees.

Theoretically, any number of teeth per disc/cup can be chosen which gives freedom of choice in step angle not possible with the common hybrid stepping motor designs.

$$\text{Possible step angles} = \frac{360}{n \times z} \text{ degrees,}$$

where n = number of phases

z = number of teeth/disc

for n = 4, z = 50, step angle =  $360/4 \times 50 = 1,8^\circ$  (200 steps/rev)

n = 4, z = 48, step angle =  $360/4 \times 48 = 1,875^\circ$  (192 steps/rev)

n = 4, z = 24, step angle =  $360/4 \times 24 = 3,75^\circ$  ( 96 steps/rev)

Fig. 6 shows the position of the four rotor discs in a motor with a step angle of 22,5°.

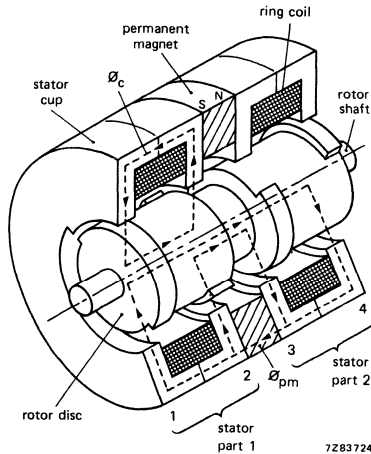

Fig. 5 Ring-coil hybrid stepping motor, showing the paths of the permanent-magnet flux  $\phi_{pm}$  and coil flux  $\phi_c$  for one coil excitation mode. For this mode  $\phi_c$  adds to  $\phi_{pm}$  in disc 1 and subtracts from it in disc 2.

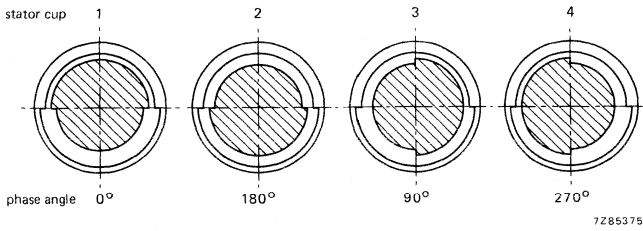

Fig. 5b The positions of the four rotor discs of Fig. 5a.

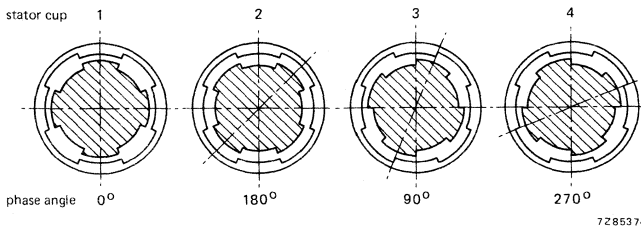

Fig. 6 Positions of the rotor discs with respect to each other for a motor with four teeth on stator cups and rotor discs.

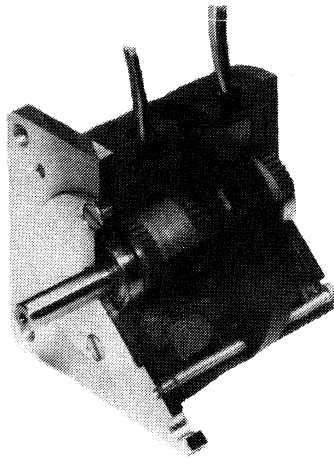

Fig. 7 Industrial design of the Philips hybrid motor, showing a cut-away view of the industrial design with 50 teeth on stator and rotor.

## PRACTICAL ASPECTS OF STEPPING MOTORS

Proper selection of the right stepping motor for a specific application calls for a thorough understanding of the characteristics of the motor and its drive circuitry. Figure 8 shows schematically the four constituent parts of a stepping motor system together with the most important aspects of each. These will be briefly considered below.

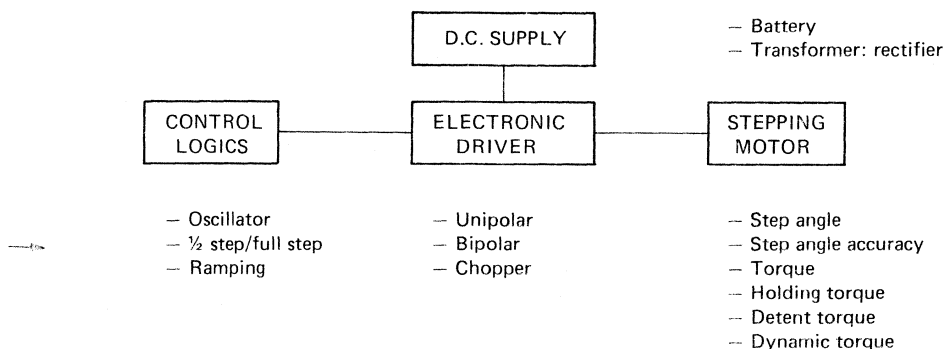

Fig. 8.

### THE STEPPING MOTOR

#### Step angle

The standard step angles are:

- 0,9° – 400 steps per revolution
- 1,8° – 200 steps per revolution
- 3,6° – 100 steps per revolution
- 3,75° – 96 steps per revolution
- 7,5° – 48 steps per revolution
- 15,0° – 24 steps per revolution

Any incremental movement can be made that is a multiple of these step angles. For example, 6 steps of 7,5° would give a movement of 45°.

#### Positional accuracy

The no load (or constant) accuracy of each step is specified for each motor in the range. For example, motor 9904 112 35... has a step angle of 7,5° and will position within 20' (i.e., 5%) whether it moves 1 step or 1000. The error is non-cumulative and averages to zero in 4 steps, i.e., 360 electrical degrees. Every four steps the rotor returns to the same position with respect to magnetic polarity and flux paths.

For this reason, when very accurate positioning is required, it is advisable to divide the required movement into multiples of four steps. This is known as the 4-step mode.



## Torque

Three types of torque need to be considered in stepping motors:

### *Holding torque*

At standstill, when energized, a certain amount of torque is required to deflect a motor 1 step. This is known as the holding torque and is specified for each motor in the range. When a torque is applied that exceeds the holding torque the motor will rotate continuously. The holding torque is normally higher than the working torque and acts as a strong brake in holding a load in position. The higher it is the more accurately the load is retained in position.

### *Detent torque*

Due to their permanent magnets, permanent magnet and hybrid stepping motors have a braking torque even when unenergized. This is the detent torque.

### *Working (dynamic) torque*

The dynamic characteristics of a stepping motor are described by the curves of torque versus stepping rate. Typical curves are shown in Fig. 9.

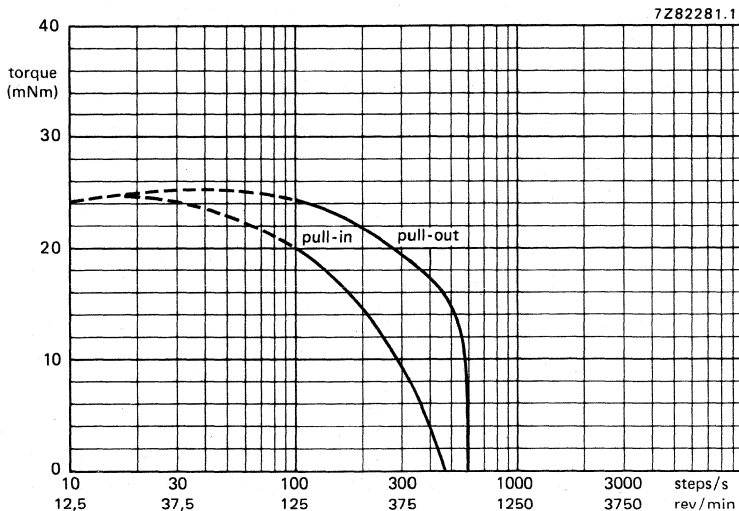

Fig. 9 Torque versus stepping rate of motor 9904 112 31104.

The *pull-in curve* shows the load a motor can start and stop without losing steps when operated at a constant stepping rate.

The *pull-out curve* shows the torque available when the motor is gradually accelerated to and decelerated from its required working speed. The area between the two curves is known as the *slew range*.

These characteristic curves are the key to the selection of the right motor and the control and drive circuits. Some hints on defining the requirements and on the applicable calculations required are given in the following section.

**Overshoot**

When making a single step a rotor tends to overshoot and oscillate about its final position as shown in Fig. 10. This is normal behaviour for any pulsed dynamic system. The actual response depends on the load and on the power input provided by the drive. The response can be modified by increasing the frictional load or by adding mechanical damping. However, mechanical dampers such as friction discs or fluid flywheels add to system cost and complexity. It is usually better to damp electronically.

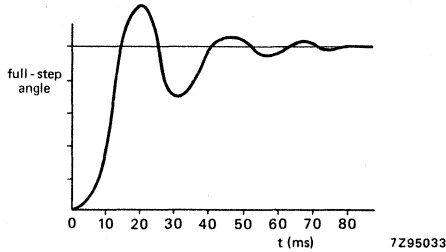

Fig. 10 Single-step response.

Two methods are commonly used — the simplest being to delay the final pulse in an incremental train. Alternatively, every pulse, or just the final pulse in a train can be modified (as shown in Fig. 11) into:

- A forward pulse at  $t_0$
- A reverse pulse at  $t_1$
- A final forward pulse at  $t_2$

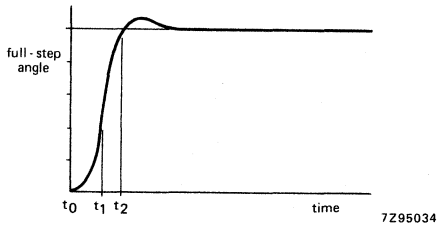

Fig. 11 Electronically damped response.

**Step function — multiple stepping**

There are often several alternatives when a given incremental movement must be made. For example, a rotation of  $90^\circ$  can be reached in 6 steps of a  $15^\circ$  motor, 12 steps of a  $7.5^\circ$  motor or in 50 steps of a  $1.8^\circ$  motor.

Generally, a movement executed in a large number of small steps will result in less overshoot, be stiffer and more accurate than one executed in larger steps. Also there is more opportunity to control the velocity by starting slowly, accelerating to full speed and then decelerating to a standstill with minimum oscillation about the final position.

### Resonance

A stepping motor operated on no-load over its entire operating frequency range will disclose resonance points that are either audible or can be detected by vibration sensors. If any are objectionable, these frequencies should be avoided, a softer drive used, extra inertia or external damping added.

### DRIVE METHODS

The normal drive method is the 4-step sequence mentioned in the section on positional accuracy. However, other methods can be used depending on the coil configuration and the logic pattern in which the coils are switched.

#### Unipolar or bipolar?

There are three types of motor in the range: 4-phase unipolar, 2-phase and 4-phase bipolar.

*4-phase unipolar* motors have two coils on one bobbin for each stator (bifilar winding). The two-stator stepping motors have, therefore, 4 coils. Because the coils occupy the same space as a single coil in equivalent bipolar types, the wire is thinner and coil resistance higher.

Unipolar motors may require only a simple drive circuit — only four power transistors instead of eight. Moreover, the switching time, needed to prevent two switched-on transistors short-circuiting the supply, as with bipolar drives, is less critical.

So unipolar motors with simplified drive have less torque at low stepping rates than their bipolar counterparts, although at higher stepping rates it is the same.

*Bipolar* motors have but 1 coil per bobbin so that 2-stator motors have 2 coils and 4-stator motors 4 coils. Stator flux is reversed by reversing the currents through the winding. As shown in Fig. 12, a push-pull bipolar drive is needed. Care must be taken with switching times to ensure that two opposing transistors are not switched-on at the same time. Properly operated, bipolar windings give optimum motor performance at low to medium stepping rates.

#### Wave drive

Energizing one winding at a time, as shown in Fig. 12, is called wave excitation. It produces the same increment as the 4-step sequence. Since only one winding is energized, holding torque and working torque are reduced by 30%. This can, within limits, be compensated by increasing supply voltage. Advantage of this form of drive is higher efficiency, but at the cost of reduced step accuracy.

#### Half-step mode

It is also possible to step a motor in a half-step sequence, thus producing half steps, 3,75° steps from a 7,5° motor, for example. A possible drawback for some applications is that the holding torque is strong and weak on alternate steps, because on one step two windings are energized and on the other only one. Also, because winding and flux paths differ on alternate steps, accuracy will be worse than when full-stepping. The principle of the half-step is shown in Fig. 13 and the proper switching sequence in Fig. 12.

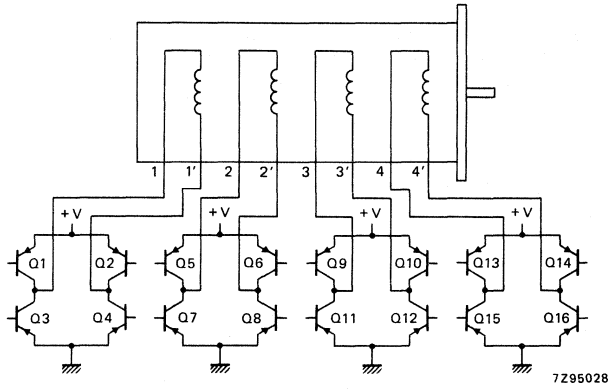

Fig. 12a.

BIPOLAR - 4 PHASE

	Q2Q3	Q1Q4	Q6Q7	Q5Q8	Q10Q11	Q9Q12	Q14Q15	Q13Q16
1	ON	OFF	OFF	ON	OFF	ON	OFF	ON
2	ON	OFF	ON	OFF	OFF	ON	OFF	ON
3	ON	OFF	ON	OFF	ON	OFF	OFF	ON
4	ON	OFF	ON	OFF	ON	OFF	ON	OFF
5	OFF	ON	ON	OFF	ON	OFF	ON	OFF
6	OFF	ON	OFF	ON	ON	OFF	ON	OFF
7	OFF	ON	OFF	ON	OFF	ON	ON	OFF
8	OFF	ON	OFF	ON	OFF	ON	OFF	ON
1	ON	OFF	OFF	ON	OFF	ON	OFF	ON

FULL STEP

↓ ↑  
CW CCW

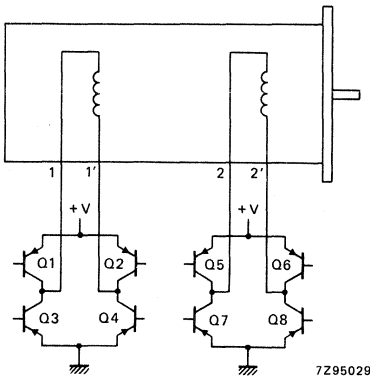

7295029

Fig. 12b.

BIPOLAR - 2 PHASE

	Q2Q3	Q1Q4	Q6Q7	Q5Q8
1	ON	OFF	OFF	ON
2	ON	OFF	ON	OFF
3	OFF	ON	ON	OFF
4	OFF	ON	OFF	ON
1	ON	OFF	OFF	ON

FULL STEP

↓ ↑  
CW CCW

1	ON	OFF	OFF	ON
2	ON	OFF	OFF	OFF
3	ON	OFF	ON	OFF
4	OFF	OFF	ON	OFF
5	OFF	ON	ON	OFF
6	OFF	ON	OFF	OFF
7	OFF	ON	OFF	ON
8	OFF	OFF	OFF	ON
1	ON	OFF	OFF	ON

HALF STEP

↓ ↑  
CW CCW

1	ON	OFF	OFF	OFF
2	OFF	OFF	ON	OFF
3	OFF	ON	OFF	OFF
4	OFF	OFF	OFF	ON
1	ON	OFF	OFF	OFF

WAVE DRIVE

↓ ↑  
CW CCW

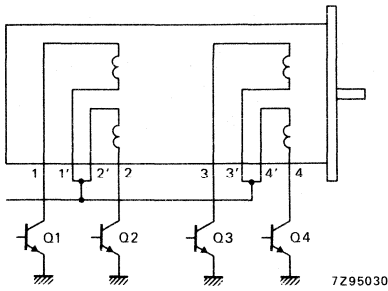

Fig. 12c.

UNIPOLAR - 4 PHASE

	Q1	Q2	Q3	Q4
1	ON	OFF	OFF	ON
2	ON	OFF	ON	OFF
3	OFF	ON	ON	OFF
4	OFF	ON	OFF	ON
1	ON	OFF	OFF	ON

1	ON	OFF	OFF	ON
2	ON	OFF	OFF	OFF
3	ON	OFF	ON	OFF
4	OFF	OFF	ON	OFF
5	OFF	ON	ON	OFF
6	OFF	ON	OFF	OFF
7	OFF	ON	OFF	ON
8	OFF	OFF	OFF	ON
1	ON	OFF	OFF	ON

1	ON	OFF	OFF	OFF
2	OFF	OFF	ON	OFF
3	OFF	ON	OFF	OFF
4	OFF	OFF	OFF	ON
1	ON	OFF	OFF	OFF

FULL STEP

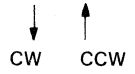

HALF STEP

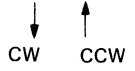

WAVE DRIVE

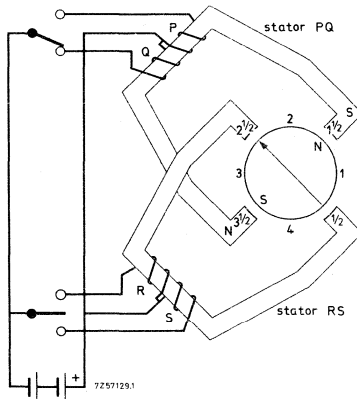
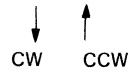

Fig. 13 Principle of half step mode.

## SUPPLY

When a motor is operated at a fixed rated voltage its torque output decreases as step rate rises. This is because the increasing back EMF and the rise time of the coil current limits the power actually delivered to the motor. The effect is governed by the ratio of inductance to resistance ( $L/R$ ) in the circuit.

The effect can be compensated by either increasing the power supply voltage to maintain constant current as stepping rate increases, or by increasing supply voltage by a fixed amount and adding series resistors to the circuit.

### L/R drive

Series resistors are chosen to give required  $L/R$  ratio; resistors three times the winding resistance would give a ratio of  $L/4R$ . Their rating should be:

$$\text{watts} = (\text{current per winding})^2 \times R$$

Supply voltage would then be increased to four times the motor rated voltage to maintain rated current. If the increased power consumption is objectionable some other drive method such as a bi-level voltage supply or a chopper supply should be used, as shown in Fig. 14.

Note: because of their higher winding resistance unipolar motors have a better  $L/R$  ratio than their bipolar equivalents.

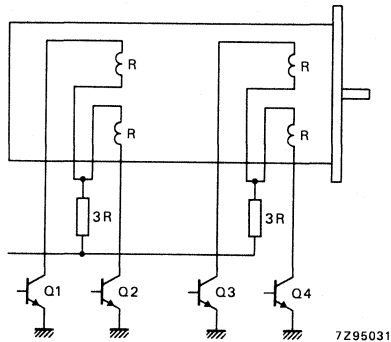

Fig. 14  $L/4R$  drive.

**Bi-level drive**

With a bi-level drive the motor is operated below rated voltage at zero steps/s (holding) and above rated voltage when stepping. It is most efficient for fixed stepping rates. The high voltage may be turned on by current sensing resistors or, as in the circuit of Fig. 15, by means of the inductively generated turn-off current spikes. At zero steps/s the windings are energized from the low voltage. As the windings are switched in the 4-step sequence, suppression diodes D1, D2, D3 and D4 turn on the high voltage supply transistors S1 and S2.

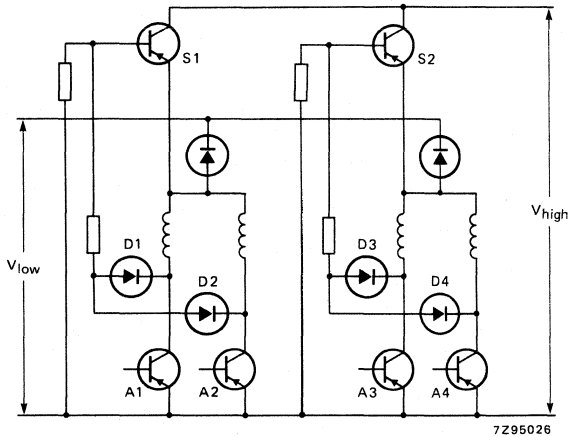

Fig. 15 Unipolar bi-level drive.

**Chopper drive**

A chopper drive maintains current at an average level by switching the supply on until an upper current level is reached and then switching it off until a lower level is reached. A chopper drive is best suited to fast acceleration and variable frequency applications. It is more efficient than an analogue constant current regulated supply. In the chopper circuit shown in Fig. 16,  $V+$  would be typically 5 to 10 times the motor rated voltage.

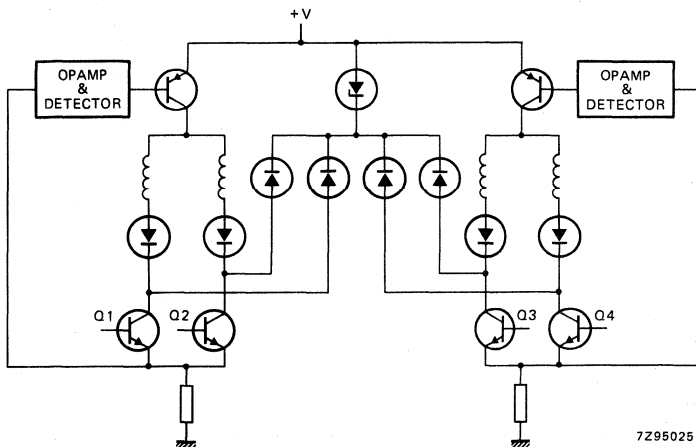

Fig. 16 Unipolar chopper drive.

**Spike suppression**

When windings are turned-off, high-voltage spikes are induced which could damage the drive circuit if not suppressed. They are usually suppressed by a diode across each winding. A disadvantage is that torque output is reduced unless the voltage across the transistors is allowed to build up to about twice the supply voltage. The higher this voltage the faster induced fields and currents collapse and performance is, therefore, better. For this reason a zener diode or series resistor is usually added as in Fig. 17.

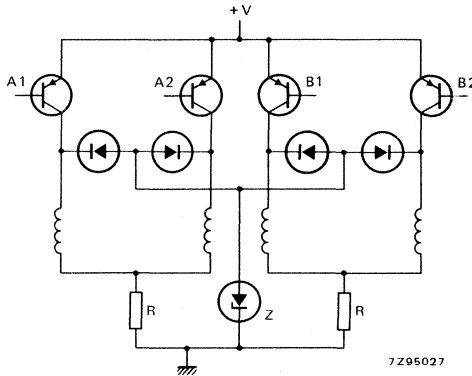

Fig. 17 Voltage suppression circuit.

**Performance limitations**

At standstill or low step rates, increasing the supply voltage produces proportionally higher torque until the motor magnetically saturates. Near saturation the motor becomes less efficient so that increased power is unjustifiable.

The maximum speed of a stepping motor is limited by inductance and eddy current losses. At a certain step rate the heating effect of these losses limits any further attempt to get more speed or torque out a motor by driving it harder.



## TYPICAL STEPPING MOTOR CALCULATION

**PULL-IN CURVE** to be used where load is purely frictional and no provision is made for acceleration.

For example: A frictional load of 45 mNm must be moved 67,5° in 0,06 s or less. No provision is made for acceleration.

Solution: 67,5° is 9 steps for a motor with a step angle of 7,5°.

A stepping rate of  $v = \frac{9}{0,06} = 150$  steps/s or higher is needed.

From Fig. 18 (the curves for motor type 9904 112 35214) the maximum pull-in rate at 45 mNm is 180 steps/s.

Clearly, motor type 9904 112 35214 can safely be used at 150 steps/s where a torque of over 50 mNm is available.

**PULL-OUT CURVE** to be used in conjunction with the equation torque = inertia x acceleration ( $T = J\alpha$ ) when the load is inertial and/or acceleration control is provided. In the above equation  $\alpha$  is in radians/s<sup>2</sup>.

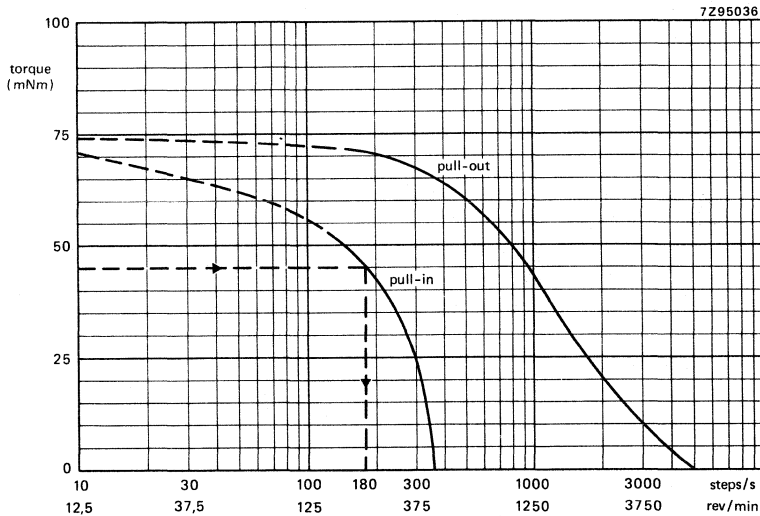

Fig. 18 Torque versus stepping rate of motor 9904 112 35214.

**RAMPING**

A voltage controlled oscillator with associated charging capacitor is usually used for acceleration control (or ramping). Different RC constants will give different ramping times. Fig. 19 shows a typical curve of step rate against time for an incremental movement with equal acceleration and deceleration times.

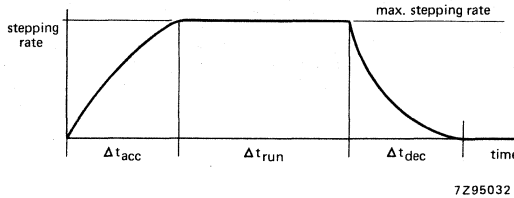

Fig. 19 Step rate versus time.

Frequency division can also be used for acceleration control. For example, starting at quarter rate then accelerating successively to half, three-quarters and, finally, to full frequency rate.

**1. Applications where acceleration or deceleration time is allowed**

$$T_J = J_T \times \frac{\Delta v}{\Delta t} \times K$$

Where  $T_J$  = Torque

$J_T$  = rotor inertia plus load inertia ( $g.m^2$ )

$K = \frac{2\pi}{\text{steps/rev}}$  (bringing steps/s to radians/s)

$K = 0,0314$  for  $1,8^\circ$  step angle

$= 0,065$  for  $3,75^\circ$  step angle

$= 0,130$  for  $7,5^\circ$  step angle

$= 0,261$  for  $15^\circ$  step angle

Applications using acceleration ramping sometimes require a series of estimates before a final decision is made. However, these take little time, as can be seen in the example below.

For example: Frictional torque plus inertial load with acceleration control.

An assembly device must move 4 mm in less than 0,5 s. The motor drives a lead screw through a gear. Gear and lead screw having been so selected that the 4 mm movement is made in 100 steps of a  $7,5^\circ$  motor. The total inertial load (rotor + gear + lead screw) is  $25 \times 10^{-4} g.m^2$ . The frictional load  $T_F$  is 4 mNm.

$$v = \frac{100 \text{ steps}}{0,5 \text{ s}} = 200 \text{ steps/s}$$

So a stepping motor must be selected that delivers more than 4 mNm at a step rate higher than 200 steps/s. Type 9904 112 32101 seems a possibility (see the curve of Fig. 20).

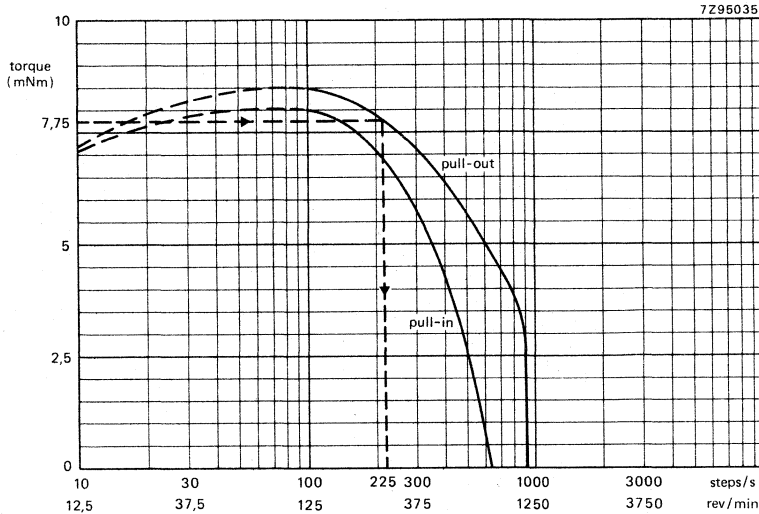

Fig. 20 Torque versus stepping rate, motor 9904 112 32101.

Make a first estimate of a working rate (lower than maximum running rate) and determine the torque available to accelerate the inertia (excess over  $T_F$ ). From the Fig. 20, the motor delivers 7,75 mNm at 210 steps/s.

$$T_I - T_F = 7,75 - 4 = 3,75 \text{ mNm}$$

Apply a safety factor of 60%.

$$3,75 \times 0,6 = 2,25 \text{ mNm}$$

Calculate acceleration time using the equation:

$$T_J = J_T \times \frac{\Delta v}{\Delta t} \times K$$

$$2,25 = \frac{25 \times 10^{-4} \times 210 \times 0,13}{\Delta t}$$

Acceleration (and deceleration) time is, therefore, 0,03 s

Number of steps to accelerate and decelerate is:

$$N_A + N_D = \frac{v}{2} \Delta t \times 2 = v \Delta t = 210 \times 0,03 = 7 \text{ steps}$$

Time at the working rate is:

$$\Delta t_{\text{run}} = \frac{N_T - (N_A + N_D)}{\text{working rate}} = \frac{100 - 7}{210} = 0,443 \text{ s}$$

Total time to move is:

$$\Delta t_{\text{run}} + \Delta t_{\text{acc}} + \Delta t_{\text{dec}} = 0,433 + 0,03 + 0,03 = 0,503 \text{ s}$$

This time very slightly exceeds that allowed, but it is a first estimate and allows us to decide which way to go — whether to accept the slightly longer time or to recalculate at a slightly higher stepping rate, say 220 steps/s. Torque will be very slightly less, which means that acceleration takes fractionally longer, but total time will be less.

## 2. Applications where no acceleration time is allowed

Although no acceleration time is allowed the motor may lag up to 2 steps (180 electrical degrees). If the motor accelerates from zero steps/s to  $v$  steps/s, there will be a lag time,  $\Delta v$  of  $\frac{v}{2}$  s.

The torque equation is, therefore:

$$T = J_T \times \frac{v^2}{2} \times K$$

Where the symbols have the same significance as before.

For example: Friction plus inertia with no acceleration ramping.

A stepping motor is to be used to drive a digital tape capstan. The frictional drag is 6 mNm and the capstan inertia is  $8 \times 10^{-4}$  g.m<sup>2</sup>. The capstan must rotate in increments of 7,5° at 170 steps/s.

Select a motor with a torque in excess of 6 mNm at 170 steps/s, say the 9904 112 32204 motor.

Total inertia = rotor inertia + load inertia

$$\begin{aligned} J_T &= J_R + J_L \\ &= (2,6 \times 10^{-4}) + (8 \times 10^{-4}) \text{ g.m}^2 \\ &= 10,6 \times 10^{-4} \text{ g.m}^2 \end{aligned}$$

There is no acceleration ramping so:

$$T_J = J_T \times \frac{v^2}{2} \times K \quad (K \text{ is } 0,13)$$

$$T_J = 10,6 \times 10^{-4} \times \frac{170^2}{2} \times 0,13 = 2 \text{ mNm}$$

Total torque =  $T_F + T_J = 6 + 2 = 8 \text{ mNm}$

Referring to the pull-out curve in Fig. 21 we see that the 9904 112 32204 motor can deliver 9,2 mNm at 170 steps/s. Which means that a substantial (15%) safety margin is also available.

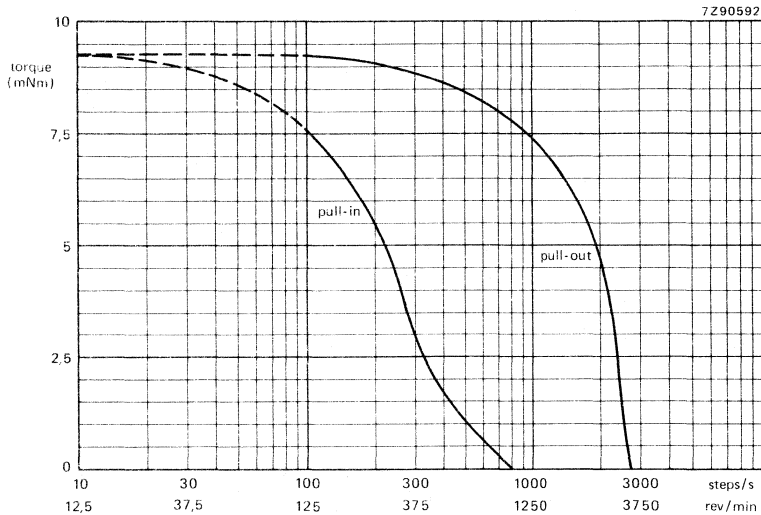

Fig. 21 Torque versus stepping rate, motor 9904 112 32204.

### SUMMARY OF KEY TORQUE EVALUATIONS

The speed-torque characteristic curves are the key to selecting the right motor and control drive method for a specific application.

Define characteristics of load to be driven

Use the **pull-in** curve if no acceleration control is to be used and if the load is purely frictional.

Use the **pull-out** curve and

if ramping control provided, use  $T_J = J_T \times \frac{\Delta v}{\Delta t} \times K$

if ramping control not provided, use  $T = J_T \times \frac{v^2}{2} \times K$

## TERMINOLOGY

(in alphabetical order)

**Detent Torque:** The maximum torque that can be applied to the spindle of an unexcited motor without causing continuous rotation. Unit: mNm.

**Deviation:** The change in spindle position from the unloaded holding position when a certain torque is applied to the spindle of an excited motor. Unit: degrees.

**Holding Torque:** The maximum steady torque that can be externally applied to the spindle of an excited motor without causing continuous rotation. Unit: mNm.

**Maximum Pull-In Rate (Speed):** The maximum switching rate (speed) at which an unloaded motor can start without losing steps. Unit: steps/s (rev/min).

**Maximum Pull-Out Rate (Speed):** The maximum switching rate (speed) which the unloaded motor can follow without losing steps. Unit: steps/s (rev/min).

**Maximum Working Torque:** The maximum torque that can be obtained from the motor. Unit: mNm.

**Overshoot:** The maximum amplitude of the oscillation around the final holding position of the rotor after cessation of the switching pulses. Unit: degrees.

**Permanent Overshoot:** The number of steps the rotor moves after cessation of the switching pulses. Unit: steps.

**Phase:** Each winding connected across supply voltage.

**Pull-In Rate (Speed):** The maximum switching rate (speed) at which a frictionally loaded motor can start without losing steps. Unit: steps/s (rev/min).

**Pull-In Torque:** The maximum torque that can be applied to a motor spindle when starting at the pull-in rate. Unit: mNm.

**Pull-Out Rate (Speed):** The maximum switching rate (speed) which a frictionally loaded motor can follow without losing steps. Unit: steps/s (rev/min).

**Pull-Out Torque:** The maximum torque that can be applied to a motor spindle when running at the pull-out rate. Unit: mNm.

**Start Range:** The range of switching rates within which a motor can start without losing steps.

**Step Angle:** The nominal angle that the motor spindle must turn through between adjacent step positions. Unit: degrees.

**Stepping Rate:** The number of step positions passed by a fixed point on the rotor per second. Unit: steps/s.

**Slew Range:** The range of switching rates within which a motor can run unidirectionally and follow the switching rate (within a certain maximum acceleration) without losing steps, but cannot start, stop or reverse.

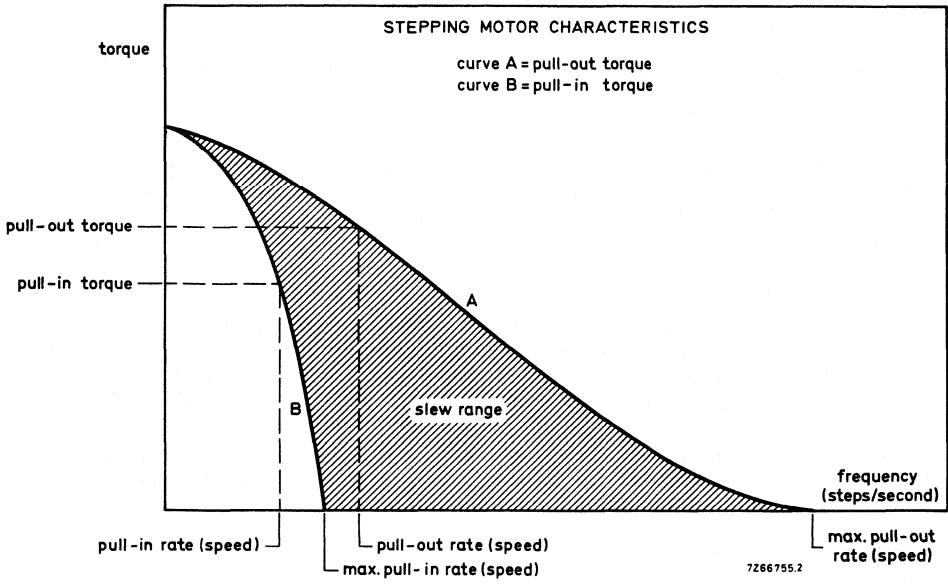

## ADDITIONAL INFORMATION TO MOTOR SPECIFICATIONS

The following pages contain full specifications for each motor type. Values given are typical, they apply at an ambient temperature of 15 °C to 35 °C, an atmospheric pressure of 860 to 1060 mbar and a relative humidity of 45 to 75%.

The following points should be noted:

### Maximum motor temperatures

Temperature increase in the motors depends upon their power consumption. Motors employing unipolar drive unit 9904 131 03006 or integrated circuit SAA1027, operate from a low supply voltage and have a low power input which limits the increase in motor temperature. If motors with unipolar drive are operated at low ambient temperatures, a higher supply voltage, giving correspondingly higher torque, is permissible.

Motors employing bipolar constant current drive operate from a high (e.g. 40 V) supply voltage and have a higher input power which causes a greater increase in motor temperature. They should either be mounted on a surface that will act as a heatsink or have forced cooling.

At ambient temperatures above 25 °C, the torque of motors, both for unipolar and bipolar drive, will decrease by approximately 0,2% per K, due to change in copper resistance and to the temperature coefficient of the magnet. There is also a derating at low ambient temperatures, more so for unipolar motors operating in the slew range: pull-in, however, is not affected.

**Instability** of a stepping motor's performance can occur under certain circumstances. The mass moment of the rotor and its load, together with the magnetic stiffness, forms a spring system which causes:

- a resonance at low stepping rates;
- hunting around the required speed at high stepping rates.

These unstable areas are indicated by broken lines on the performance curves appearing in this section.

Resonance can be minimized by applying the correct amount of friction to the motor drive-spindle.

Hunting can be minimized by attaching a "Lancaster damper" to the motor spindle. A Lancaster damper basically consists of a disc that is frictionally attached over the motor spindle. Ordinarily the disc rigidly follows the rotational speed of the spindle but when hunting occurs, it moves through a small angle in relation to the spindle and absorbs the fluctuation in speed. The mass moment of the disc and the required friction depend entirely upon the application and must be individually determined in each case.



## 4-PHASE UNIPOLAR STEPPING MOTORS

permanent magnet type

### DESCRIPTION

The motors have a 4-phase stator and a permanent magnet rotor with 24 poles (step angle of  $7^{\circ} 30'$ ) or 12 poles (step angle of  $15^{\circ}$ ). The motor coils are adapted for optimum matching to the 4-phase unipolar integrated circuit SAA1027 or to the 4-phase electronic driver module 9904 131 03006 (see relevant data sheets).

### CONNECTION DIAGRAMS

- Motors with 6 leads or connecting tags and integrated circuit SAA1027.

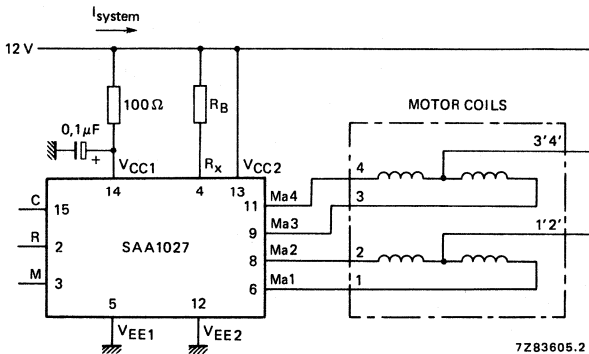

Fig. 1 Resistor value  $R_B$  can be found in Table 1. C = count input (previously T); R = reset (previously S); M = mode input to select c.w. or c.c.w. (previously R).

Table 1

motor	$R_B$		$I_{system}$
9904 112 06001	180 $\Omega$	0,67 W	200 mA
27001	150 $\Omega$	1,15 W	600 mA
28001	150 $\Omega$	1,15 W	600 mA
31001	180 $\Omega$	0,67 W	400 mA
31004	180 $\Omega$	0,67 W	400 mA
31006	180 $\Omega$	0,67 W	400 mA
32001	270 $\Omega$	0,33 W	300 mA
33004	150 $\Omega$	0,67 W	600 mA
34004	150 $\Omega$	0,67 W	600 mA
35014	180 $\Omega$	0,67 W	600 mA
35016	180 $\Omega$	0,67 W	600 mA
36014	180 $\Omega$	0,67 W	600 mA

● Motors with 8 leads and integrated circuit SAA1027

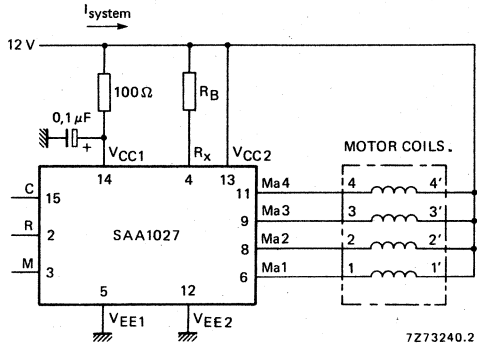

Fig. 2 Resistor value  $R_B$  can be found in Table 1.

● Motors with 6 leads or connecting tags and electronic drive unit 9904 131 03006

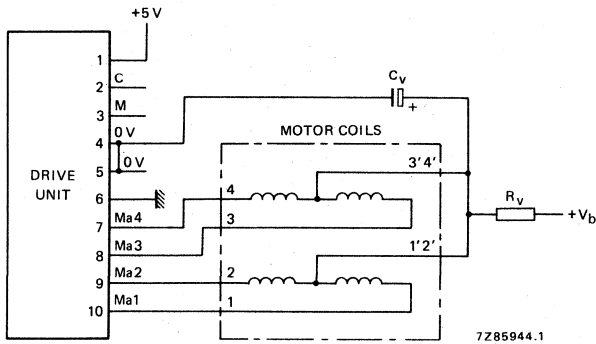

Fig. 3 Resistor value  $R_V$  and capacitor value  $C_V$  can be found in Table 2.

Table 2

motor	$R_V$	$C_V$
9904 112 31104	8,2 $\Omega$	220 $\mu F$
31106	8,2 $\Omega$	220 $\mu F$
32101	15 $\Omega$	100 $\mu F$
33104	5 $\Omega$	not applicable
34104	5 $\Omega$	not applicable
35114	6 $\Omega$	not applicable
35116	6 $\Omega$	not applicable
36114	6 $\Omega$	not applicable
9904 115 15101	0 $\Omega$	not applicable

● Motors with 8 leads and electronic drive unit 9904 131 03006

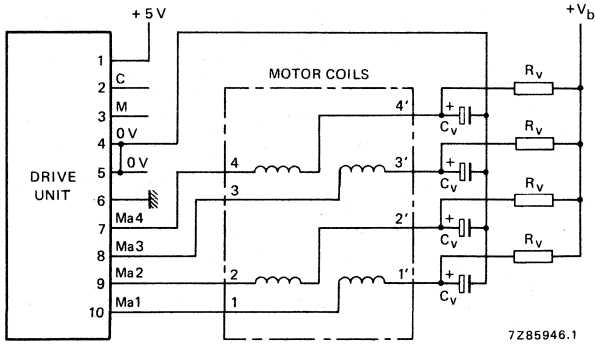

Fig. 4 Resistor value R<sub>v</sub> and capacitor value C<sub>v</sub> can be found in Table 3.

Table 3

motor	R <sub>v</sub>	C <sub>v</sub>
9904 112 06101	15 Ω	50 μF
27101	10 Ω	50 μF
28101	10 Ω	50 μF
31101	18 Ω	33 μF

## 2-PHASE BIPOLAR STEPPING MOTORS

permanent magnet type

### DESCRIPTION

The motors have a 2-phase stator and a permanent magnet rotor with 24 poles (step angle of  $7^{\circ} 30'$ ) or 12 poles (step angle of  $15^{\circ}$ ). The design is similar to the unipolar motors. The stator flux from a bipolar winding is reversed by reversing the current through the winding. With a constant current drive the bipolar motors can be used at high stepping rates. For continuous operation at high stepping rates, the temperature rise of the motor due to iron losses should be taken into account for calculating the maximum ambient temperature.

The temperature rise of the windings in bipolar motors is lower than in unipolar motors due to lower current and more windings.

### CONNECTION DIAGRAM

- Motors and electronic drive unit 9904 131 03007

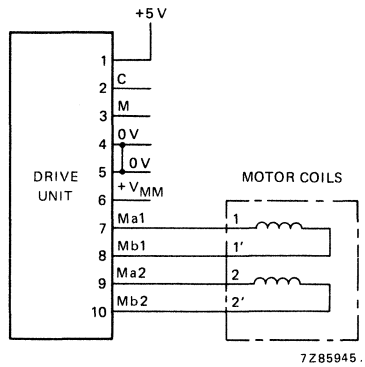

Fig. 1.

## 4-PHASE BIPOLAR STEPPING MOTORS

permanent magnet type

### DESCRIPTION

These motors have a 4-phase stator and a permanent magnet rotor with 24 poles (stepping angle  $3^{\circ} 45'$ ) or 12 poles (stepping angle  $7^{\circ} 30'$ ).

The stator flux is obtained by energizing all 4 phases. The current through one of the coils is reversed, thus reversing the flux due to it.

With a constant current drive these motors can be slewed at very high stepping rates. However, it should be noted that the motors are not designed to run continuously at high stepping rates; the iron losses in the motor will cause it to overheat.

### CONNECTION DIAGRAM

- Motors with bipolar 4-phase electronic drive unit 9904 131 03008

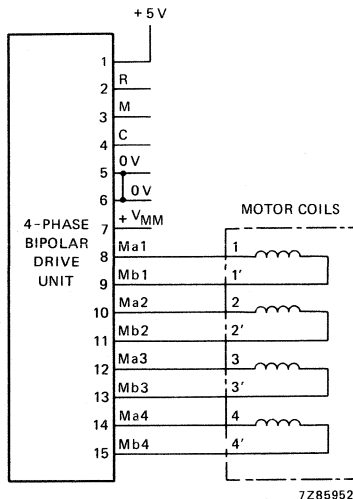
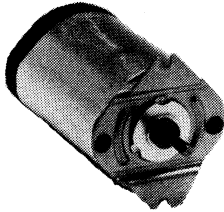

Fig. 1.

## STEPPING MOTORS



830711-01-02

ID06

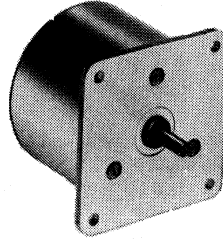

761224-10-06

ID27

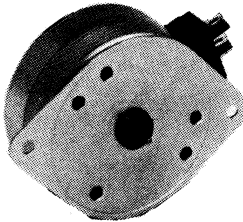

830711-01-19

ID31

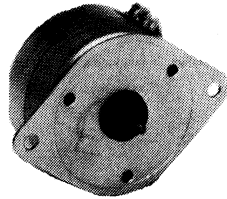

830711-01-17

ID32

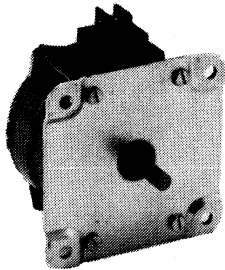

830711-01-03

ID33 - ID34

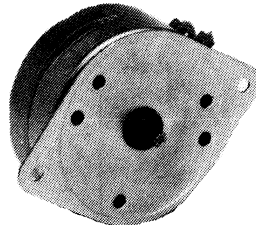

830711-01-20

ID35 - ID36

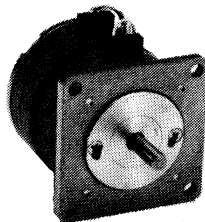

830711-01-04

HR23

## 4-PHASE UNIPOLAR STEPPING MOTORS

permanent magnet version

### QUICK REFERENCE DATA

motor type	99C4 112 06001	9904 112 06101
performance obtained with	integrated circuit SAA1027	drive unit 9904 131 03006
Step angle	7° 30'	7° 30'
Max. working torque	40 mNm	50 mNm
Holding torque	70 mNm	70 mNm
Max. pull-in	110 steps/s	200 steps/s
Max. pull-out	—	320 steps/s

### APPLICATION

Motor 9904 112 06001 is adapted for drive with integrated circuit SAA1027. This motor is for applications where the system efficiency prevails and circuitry design is simple and straight-forward.

Motor 9904 112 06101 is adapted for drive unit 9904 131 03006. This motor is ideally suited for variable speed drive where high pull-out capabilities of the motor are required.

### TECHNICAL DATA

#### Outlines

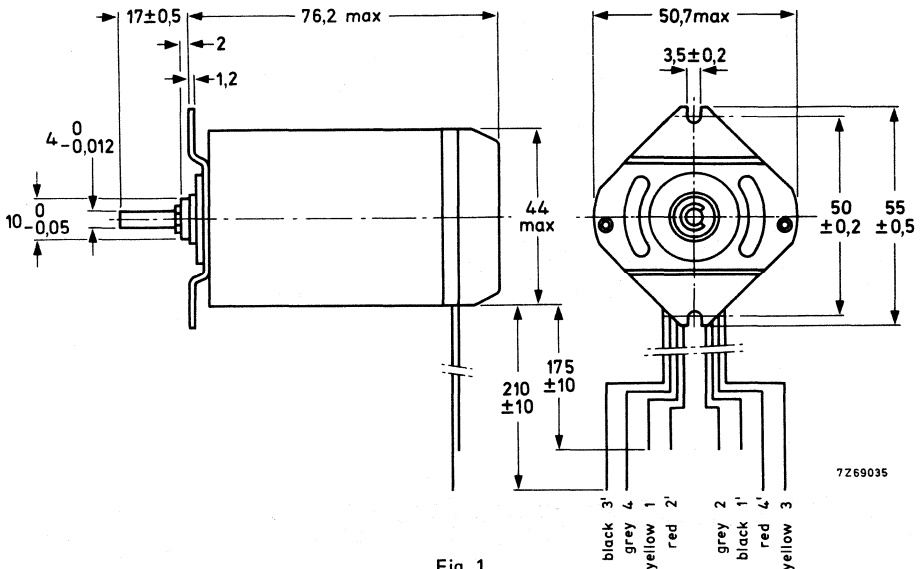

Fig. 1.

catalogue number	9904 112 06001	9904 112 06101	
Power consumption of motor only	6,4	4	W
Maximum working torque	40	50	mNm
Holding torque	70	70	mNm
Torque derating	-0,4	-0,4	%/K
Maximum pull-in rate	110	200	steps/s
Maximum pull-out rate	—	320	steps/s
Resistance per phase at 20 °C	45	12	Ω
Inductance per phase	130	35	mH
Current per phase	250	400	mA
Thermal resistance, coil-ambient	12	12	K/W
Permissible ambient temperature range	-20 to + 50	-20 to + 70	°C
Permissible storage temperature range	-40 to + 100	-40 to + 100	°C
Permissible motor temperature	120	120	°C
Insulation resistance at 500 V (CEE 10)	> 2	> 2	MΩ
Step angle	7° 30'	7° 30'	
Step angle tolerance, not cumulative	± 20'	± 20'	
Number of steps per revolution	48	48	
Direction of rotation	reversible	reversible	
Rotor inertia	90	90	gcm <sup>2</sup>
Mass	320	320	g
Maximum radial force	15	15	N
Maximum axial force	1,5	1,5	N
Bearings	slide	slide	

### Connections

The connecting leads are colour-coded (see Fig. 1) and are connected to the drive unit or to the integrated circuit as shown in General section of 4-phase unipolar stepping motors.

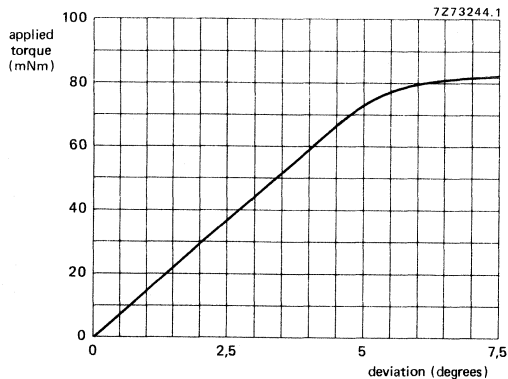

Fig. 2 Applied torque versus deviation.



Motor 9904 112 06001 with integrated circuit SAA1027

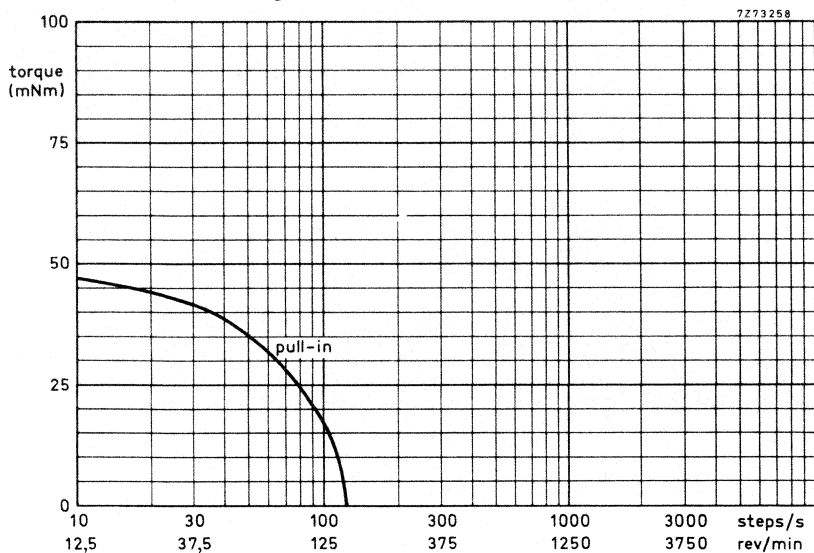

Fig. 3 Torque versus stepping rate, measured at room temperature.

Motor 9904 112 06101 with drive unit 9904 131 03006

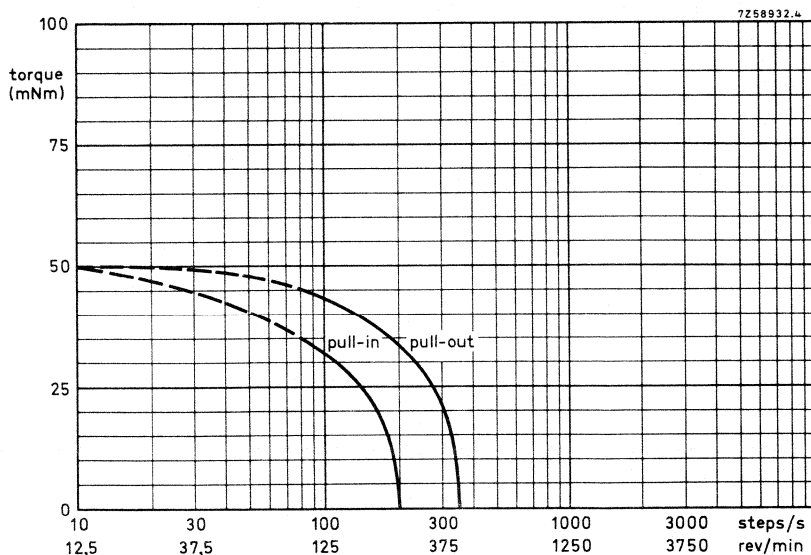

Fig. 4 Torque versus stepping rate, measured at room temperature.

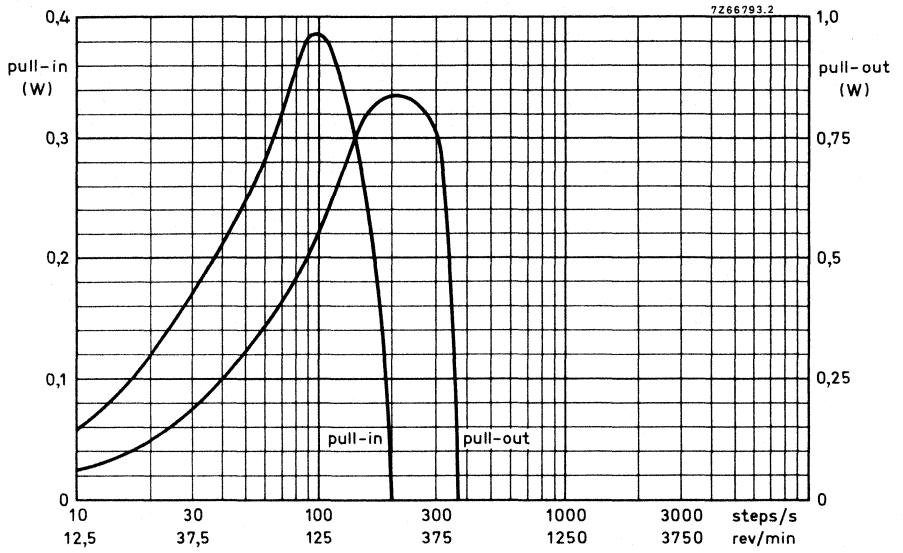

Fig. 5 Output power versus stepping rate measured at room temperature.  
(type 9904 112 06101)

## 4-PHASE UNIPOLAR STEPPING MOTORS

permanent magnet version

### QUICK REFERENCE DATA

motor type	9904 112 27001	9904 112 27101
performance obtained with	integrated circuit SAA1027	drive unit 9904 131 03006
Step angle	7° 30'	7° 30'
Max. working torque	100 mNm	110 mNm
Holding torque	140 mNm	150 mNm
Max. pull-in rate	80 steps/s	275 steps/s
Max. pull-out rate	—	275 steps/s

### APPLICATION

Motor 9904 112 27001 is adapted for drive with IC SAA1027 and offers a simple and economic solution for applications where a step-wise rotational function is wanted. Expensive and complex mechanisms can be replaced by this motor and drive.

Motor 9904 112 27101 is adapted for drive unit 9904 131 03006 and offers higher torque and speed in those applications where variable speed is needed.

Main application areas of both versions include chart recorders, X-Y plotters, paper feed mechanisms in terminal and telex printers, medical instrumentation, industrial control, etc.

The design and rigid construction of the motors ensure a long, maintenance-free life.

**TECHNICAL DATA**

catalogue number	9904 112 27001	9904 112 27101	
Power consumption of motor only	6,8	6,8	W
Maximum working torque	100	110	mNm
Holding torque	140	150	mNm
Torque derating	-0,4	-0,4	%/K
Maximum pull-in rate	80	275	steps/s
Maximum pull-out rate	-	275	steps/s
Resistance per phase at 20 °C	39	9,8	Ω
Inductance per phase	240	60	mH
Current per phase	290	580	mA
Thermal resistance, coil-ambient	8	8	K/W
Permissible ambient temperature range	-20 to + 70	-20 to + 70	°C
Permissible storage temperature range	-40 to + 100	-40 to + 100	°C
Permissible motor temperature	120	120	°C
Insulation resistance at 500 V (CEE 10)	> 2	> 2	MΩ
Step angle	7° 30'	7° 30'	
Step angle tolerance, not cumulative	± 15'	± 15'	
Number of steps per revolution	48	48	
Direction of rotation	reversible	reversible	
Rotor inertia	70	70	gcm <sup>2</sup>
Mass	610	610	g
Maximum radial force	50	50	N
Maximum axial force	20	20	N
Bearings, front	ball	ball	
Bearings, rear	slide, bronze	slide, bronze	

**Connections**

The connecting leads are colour-coded (see Fig. 5) and are connected to the IC or drive unit as shown in the General Section on 4-phase unipolar stepping motors.

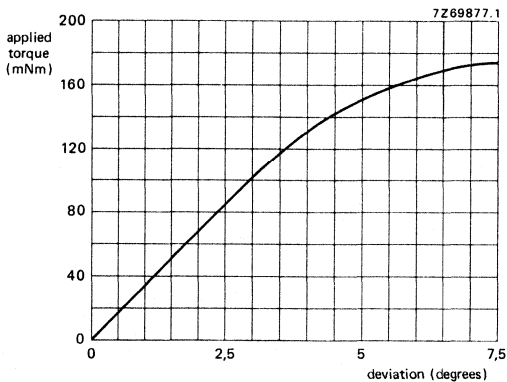

Fig. 1 Applied torque versus deviation.

Motor 9904 112 27001 with integrated circuit SAA1027

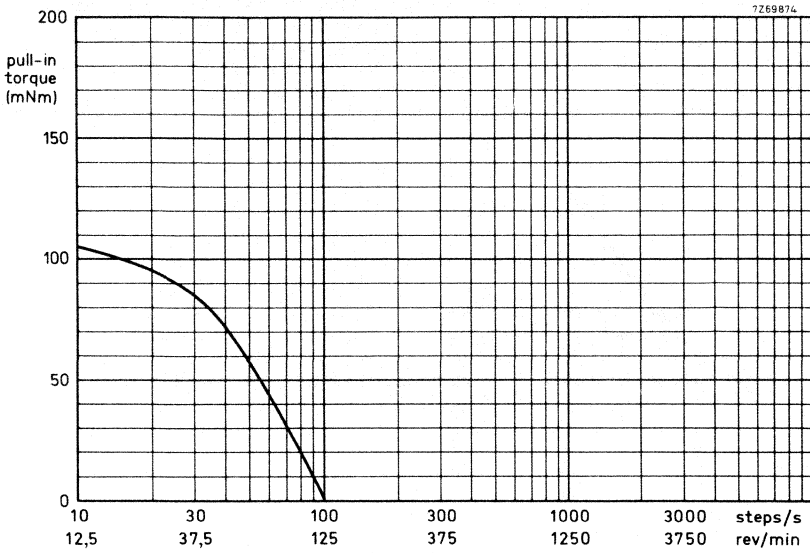

Fig. 2 Pull-in torque versus stepping rate at room temperature.

Motor 9904 112 27101 with drive unit 9904 131 03006

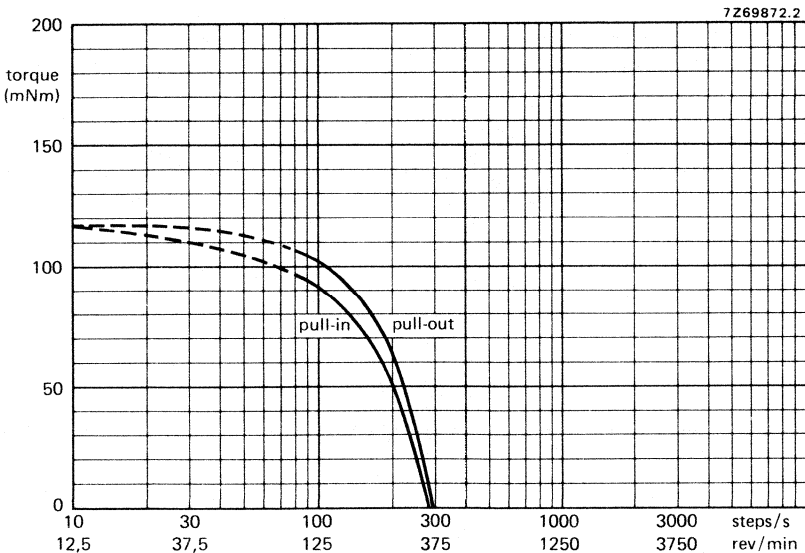

Fig. 3 Torque versus stepping rate, measured at room temperature.

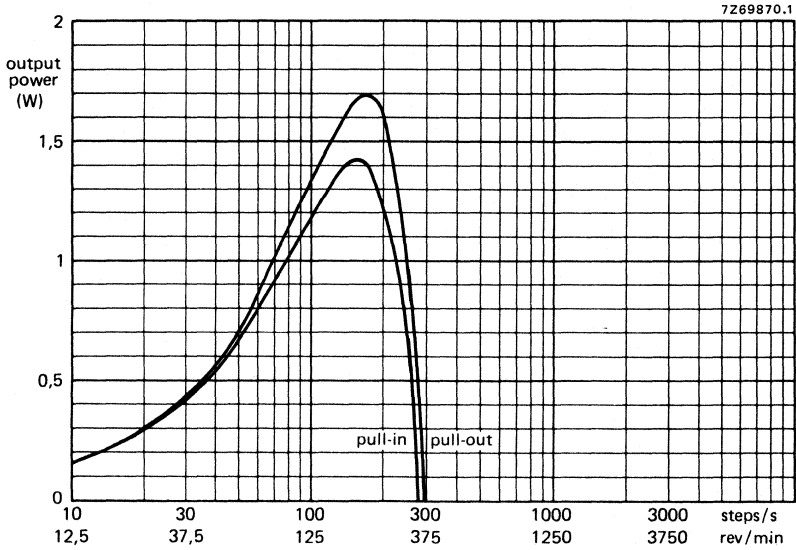

Fig. 4 Output power versus stepping rate measured at room temperature.  
(type 9904 112 27101)

**Outlines**

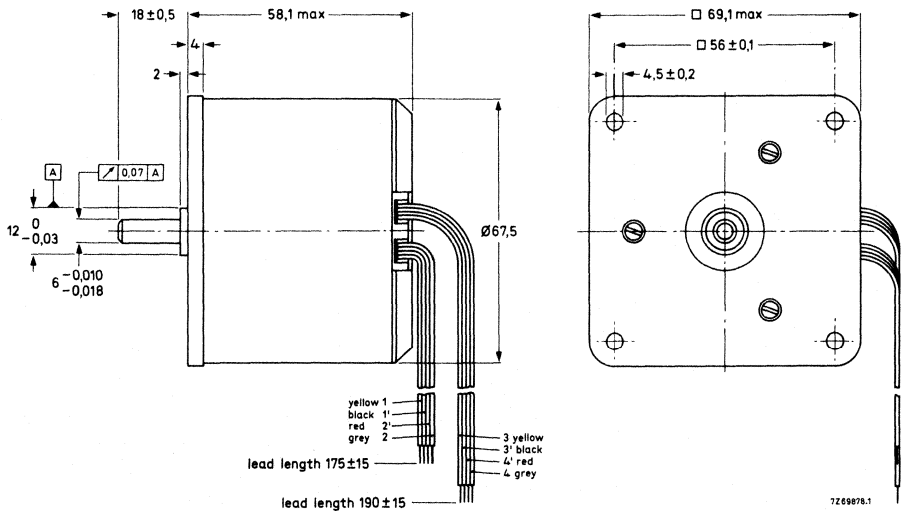

Fig. 5.

**Note**

Special versions having a spindle with a diameter of 3 mm and a length of  $8,2 \pm 0,5$  mm for use with a gearbox may be available upon request.

## 2-PHASE BIPOLAR STEPPING MOTOR

### QUICK REFERENCE DATA

Performance obtained with electronic drive unit 9904 131 03007

Step angle	7° 30'
Maximum working torque	130 mNm
Holding torque	170 mNm
Maximum pull-in rate	450 steps/s
Maximum pull-out rate	5000 steps/s

### TECHNICAL DATA

#### Outlines

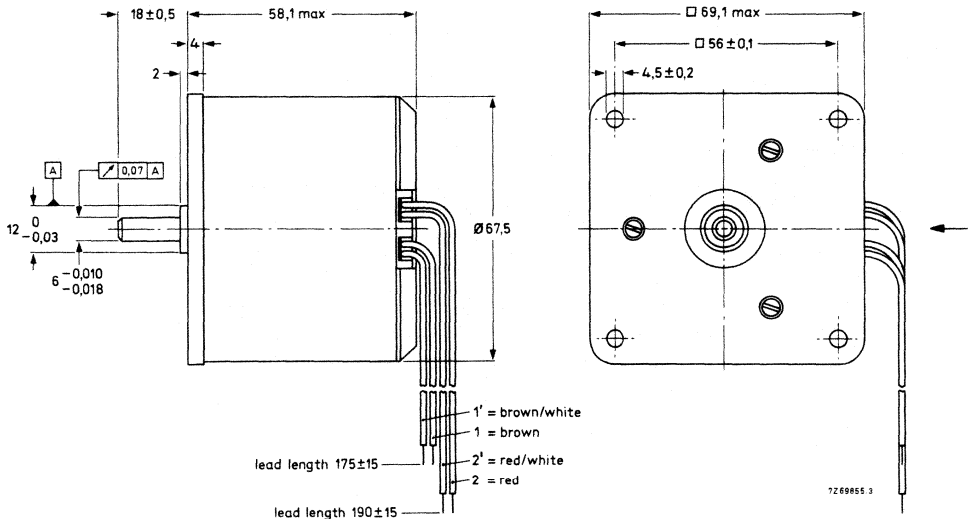

Fig. 1.

#### Note

Special versions having a spindle with a diameter of 3 mm and a length of  $8,2 \pm 0,5$  mm may be available upon request in minimum order quantities, and involve longer delivery times.

catalogue number	9904 112 27201
Power consumption of motor only	3,75 W
Maximum working torque	130 mNm
Holding torque	170 mNm
Torque derating	-0,4%/K
Maximum pull-in rate	450 steps/s
Maximum pull-out rate	5000 steps/s
Number of phases	2
Resistance per phase at 20 °C	7,5 Ω
Inductance per phase	90 mH
Current per phase	500 mA
Permissible ambient temperature range	see General section of Stepping motors
Permissible storage temperature range	-40 to + 100 °C
Permissible motor temperature	120 °C
Insulation resistance at 500 V (CEE10)	> 2 MΩ
Step angle	7° 30'
Step-angle tolerance, non-cumulative	± 15'
Number of steps per revolution	48
Direction of rotation	reversible
Rotor inertia	70 gcm <sup>2</sup>
Mass	610 g
Maximum radial force	50 N
Maximum axial force	20 N
Bearings, front	ball
rear	slide

**Connections**

The connecting leads are colour-coded and are connected to the electronic drive unit 9904 112 03007 drive as shown in General section of 2-phase bipolar stepping motors.

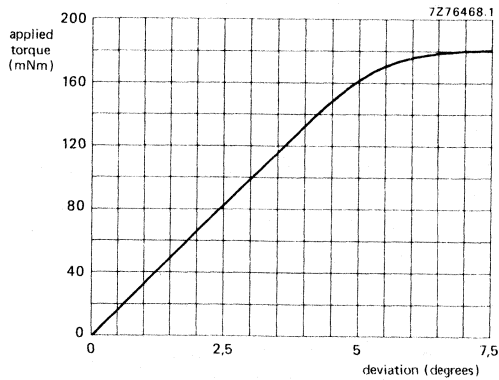

Fig. 2 Applied torque versus deviation.



Motor 9904 112 27201 with drive unit 9904 131 03007

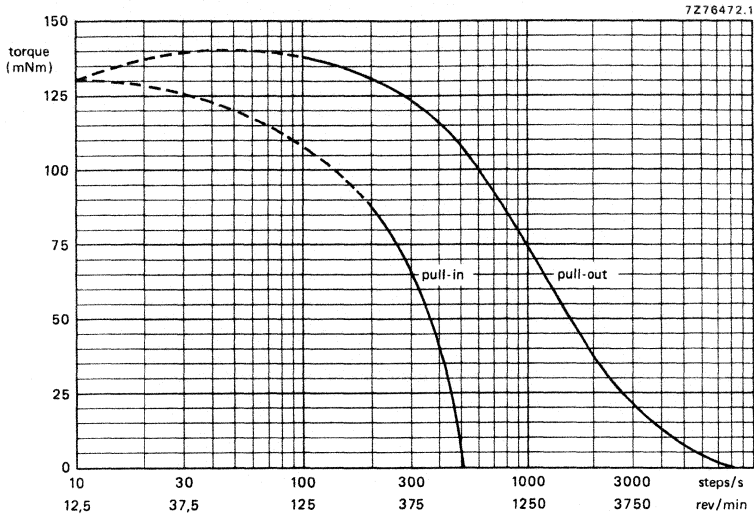

Fig. 3 Torque versus stepping rate, measured at room temperature.

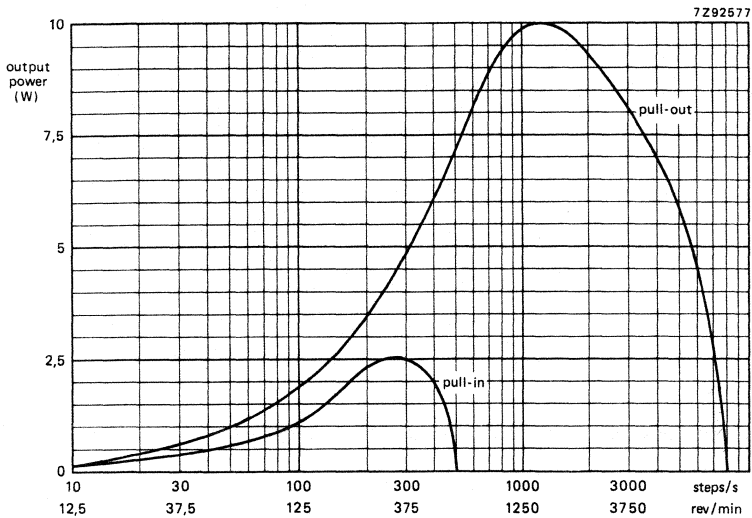

Fig. 4 Output power versus stepping rate, measured at room temperature.



## 4-PHASE UNIPOLAR STEPPING MOTORS

permanent magnet version

### QUICK REFERENCE DATA

motor type	9904 112 28001	9904 112 28101
performance obtained with	integrated circuit SAA1027	drive unit 9904 131 03006
Step angle	15°	15°
Max. working torque	60 mNm	65 mNm
Holding torque	80 mNm	85 mNm
Max. pull-in	90 steps/s	200 steps/s
Max. pull-out	—	250 steps/s

### APPLICATION

Motor 9904 112 28001 is adapted for drive with IC SAA1027 and offers a simple and economic solution for applications where a step-wise rotational function is wanted. Expensive and complex mechanisms can be replaced by this motor and drive.

Motor 9904 112 28101 is adapted for drive unit 9904 131 03006 and offers higher torque and speed in those applications where variable speed is needed.

Main application areas of both versions include chart recorders, X-Y plotters, paper feed mechanisms in terminal and telex printers, medical instrumentation, industrial control, etc.

The design and rigid construction of the motors ensure a long, maintenance-free life.

**TECHNICAL DATA**

catalogue number	9904 112 28001	9904 112 28101	
Power consumption of motor only	6,8	6,8	W
Maximum working torque	60	65	mNm
Holding torque	80	85	mNm
Torque derating	-0,4	-0,4	%/K
Maximum pull-in rate	90	200	steps/s
Maximum pull-out rate	-	250	steps/s
Resistance per phase at 20 °C	39	9,8	Ω
Inductance per phase	200	45	mH
Current per phase	290	580	mA
Thermal resistance, coil-ambient	8	8	K/W
Permissible ambient temperature range	-20 to +70	-20 to + 70	°C
Permissible storage temperature range	-40 to + 100	-40 to + 100	°C
Permissible motor temperature	120	120	°C
Insulation resistance at 500 V (CEE 10)	> 2	> 2	mΩ
Step angle	15°	15°	
Step angle tolerance, not cumulative	± 30'	± 30'	
Number of steps per revolution	24	24	
Direction of rotation	reversible	reversible	
Rotor inertia	70	70	gcm <sup>2</sup>
Mass	610	610	g
Maximum radial force	50	50	N
Maximum axial force	20	20	N
Bearings	slide (bronze)	slide (bronze)	

**Connections**

The connecting leads are colour-coded (see Fig. 5) and are connected to the IC or drive unit as shown in the General Section on 4-phase unipolar stepping motors.

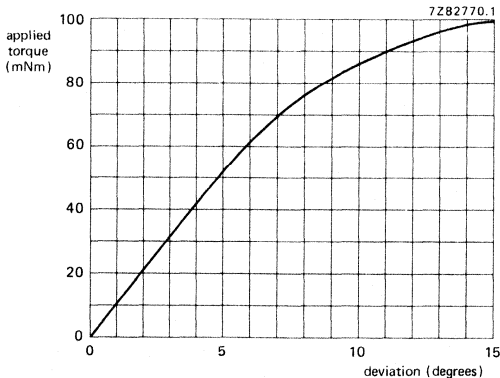

Fig. 1 Applied torque versus stepping rate.

Motor 9904 112 28001 with integrated circuit SAA1027

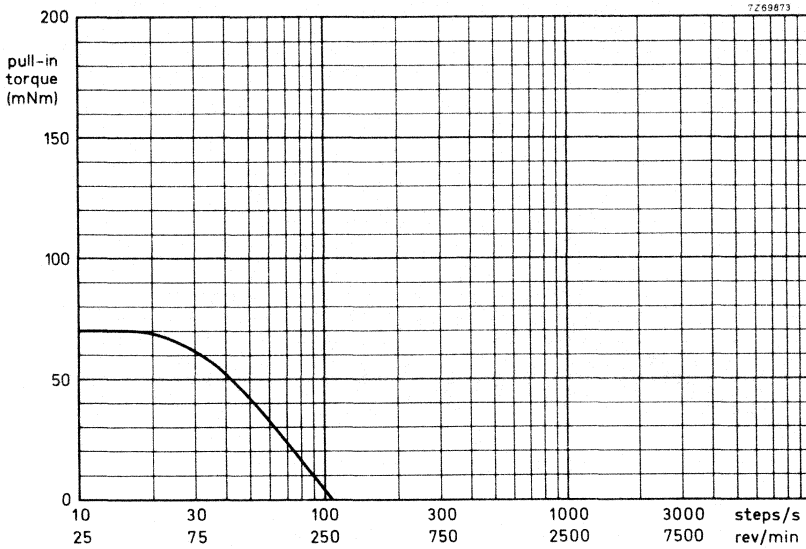

Fig. 2 Pull-in torque versus stepping rate at room temperature.

Motor 9904 112 28101 with drive unit 9904 131 03006

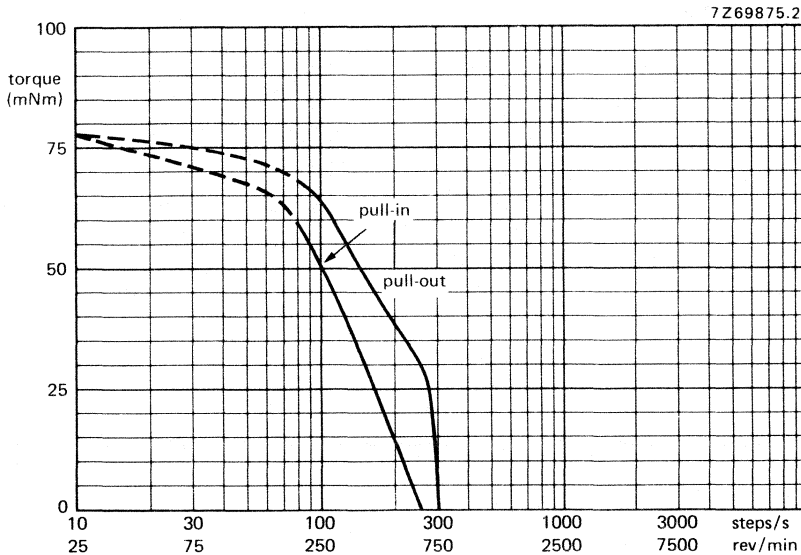

Fig. 3 Torque versus stepping rate, measured at room temperature.

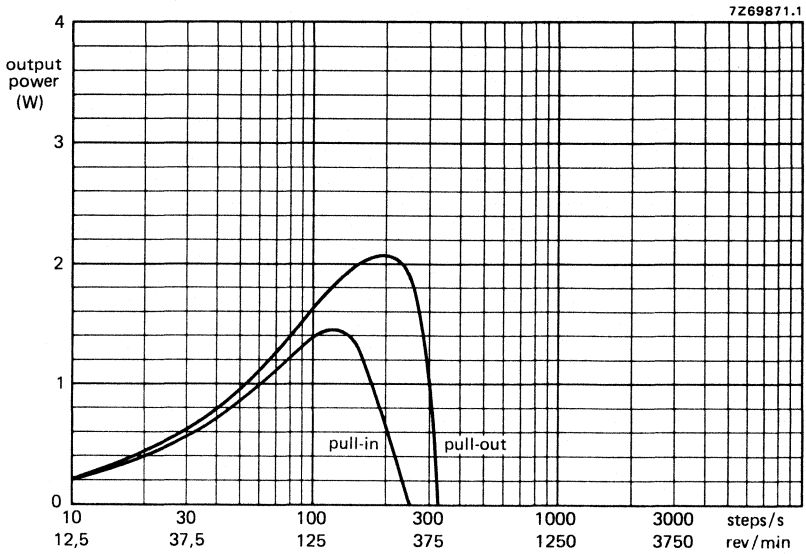

Fig. 4 Output power versus stepping rate measured at room temperature.  
 (type 9904 112 28101)

Outlines

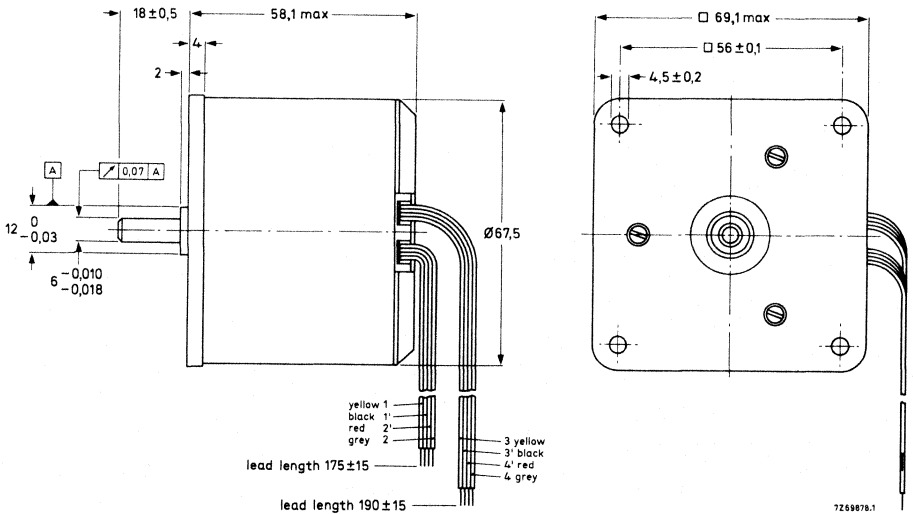

Fig. 5.

Note

Special versions having a spindle with a diameter of 3 mm and a length of  $8,2 \pm 0,5$  mm for use with a gearbox may be available upon request.

## 2-PHASE BIPOLAR STEPPING MOTOR

permanent magnet version

### QUICK REFERENCE DATA

Performance obtained with electronic drive unit 9904 131 03007

Step angle	15°
Maximum working torque	90 mNm
Holding torque	110 mNm
Maximum pull-in rate	275 steps/s
Maximum pull-out rate	3200 steps/s

### TECHNICAL DATA

#### Outlines

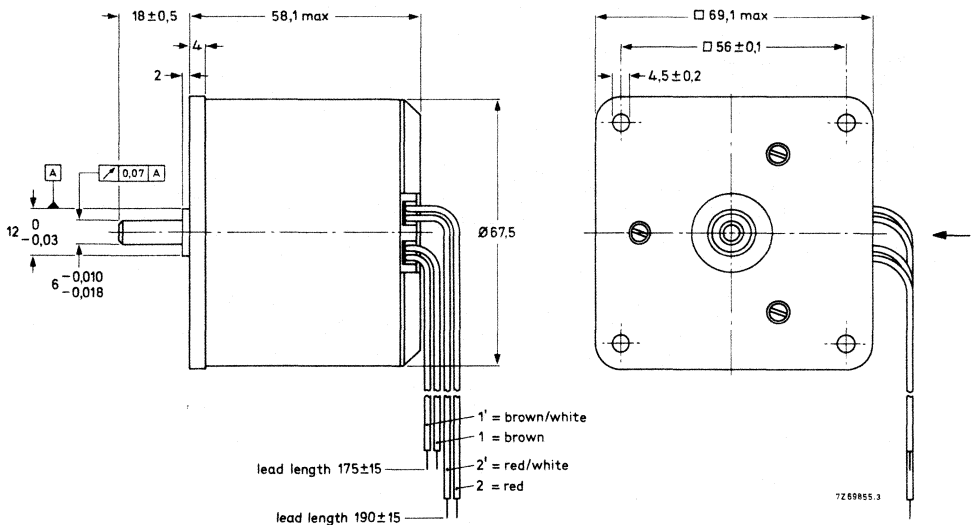

Fig. 1.

#### Note

Special versions having a spindle with a diameter of 3 mm and a length of  $8,2 \pm 0,5$  mm may be available upon request in minimum order quantities, and involve longer delivery times.

catalogue number	9904 112 28201
Power consumption of motor only	3,75 W
Maximum working torque	90 mNm
Holding torque	110 mNm
Torque derating	-0,4%/K
Maximum pull-in rate	275 steps/s
Maximum pull-out rate	3200 steps/s
Number of phases	2
Resistance per phase at 20 °C	7,5 Ω
Inductance per phase	70 mH
Current per phase	500 mA
Permissible ambient temperature range	see General section of Stepping motors
Permissible storage temperature range	-40 to + 100 °C
Permissible motor temperature	120 °C
Insulation resistance at 500 V (CEE10)	> 2 MΩ
Step angle	15°
Step-angle tolerance, non-cumulative	± 30'
Number of steps per revolution	24
Direction of rotation	reversible
Rotor inertia	70 gcm <sup>2</sup>
Mass	610 g
Maximum radial force	50 N
Maximum axial force	20 N
Bearings, front	ball
rear	slide

**Connections**

The connecting leads are colour-coded and are connected to the electronic drive unit 9904 112 03007 as shown in General section of 2-phase bipolar stepping motors.

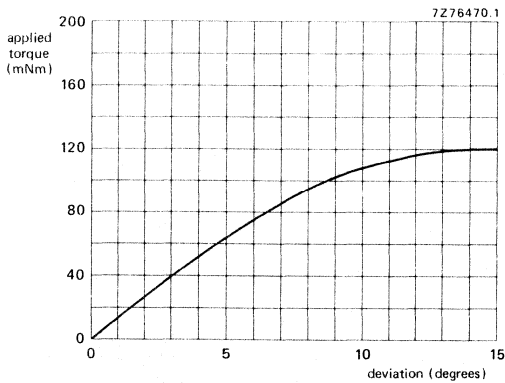

Fig. 2 Applied torque versus deviation.



Motor 9904 112 28201 with drive unit 9904 131 03007

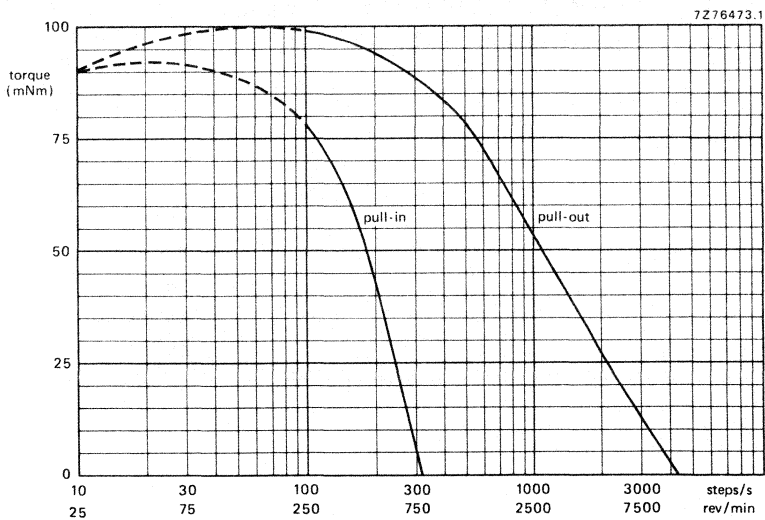

Fig. 3 Torque versus stepping rate, measured at room temperature.

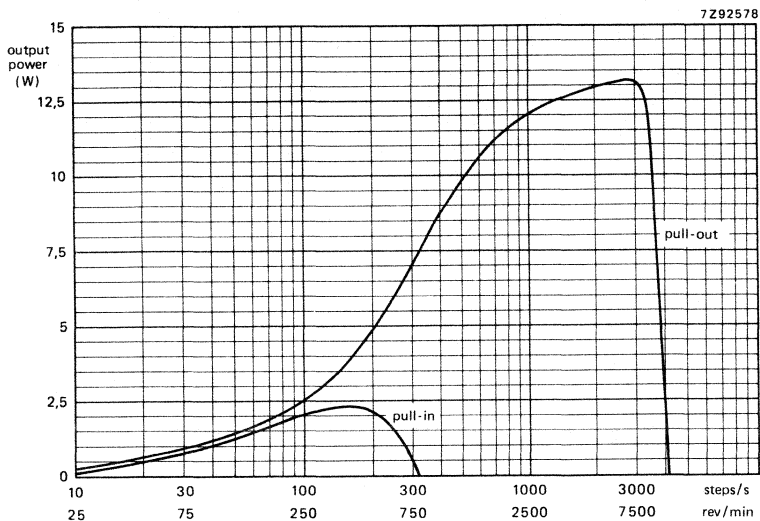

Fig. 4 Output power versus stepping rate, measured at room temperature.

## 4-PHASE BIPOLAR STEPPING MOTOR

permanent magnet version

### QUICK REFERENCE DATA

→ Performance obtained with electronic drive unit 9904 131 03008

Step angle	3° 45'
Maximum working torque	280 mNm
Holding torque	300 mNm
Maximum pull-in rate	900 steps/s
Maximum pull-out rate	12000 steps/s

### TECHNICAL DATA

#### Outlines

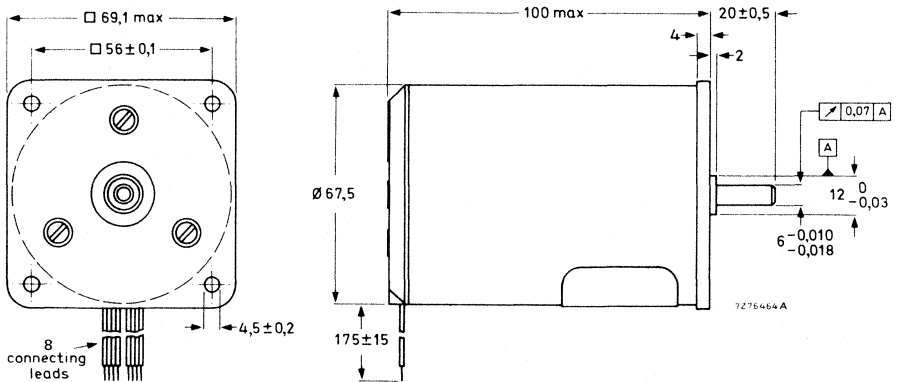

Fig. 1.

#### → Connecting leads

- |            |                   |
|------------|-------------------|
| 1 = brown  | 1' = brown/white  |
| 2 = red    | 2' = red/white    |
| 3 = orange | 3' = orange/white |
| 4 = yellow | 4' = yellow/white |

catalogue number	9904 112 29201
Power consumption of motor only	7,5 W
Maximum working torque	280 mNm
Holding torque	300 mNm
Torque derating	-0,4%/K
Maximum pull-in rate	900 steps/s
Maximum pull-out rate	12000 steps/s
Number of phases	4
Resistance per phase at 20 °C	7,5 Ω
Inductance per phase	90 mH
Current per phase	500 mA
Permissible ambient temperature range	see General section of Stepping motors
Permissible storage temperature range	-40 to + 100 °C
Permissible motor temperature	120 °C
Insulation resistance at 500 V	> 2 MΩ
Step angle	3° 45'
Step-angle tolerance, non-cumulative	± 15'
Number of steps per revolution	96
Direction of rotation	reversible
Rotor inertia	160 gcm <sup>2</sup>
Mass	1100 g
Maximum radial force	50 N
Maximum axial force	20 N
Bearings, front	ball
rear	slide

**Connections**

The connecting leads are colour-coded and are connected to the electronic drive unit 9904 112 03008 ← as shown in General section of 4-phase bipolar stepping motors.

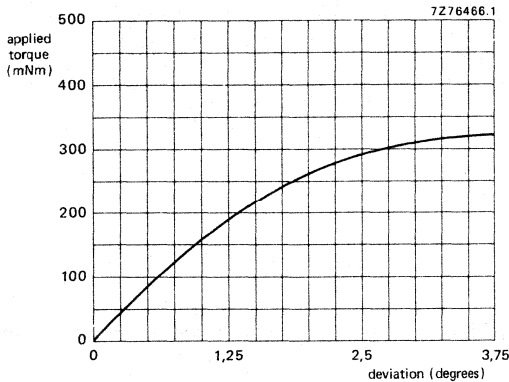

Fig. 2 Applied torque versus deviation.

→ Motor 9904 112 29201 with drive unit 9904 131 03008

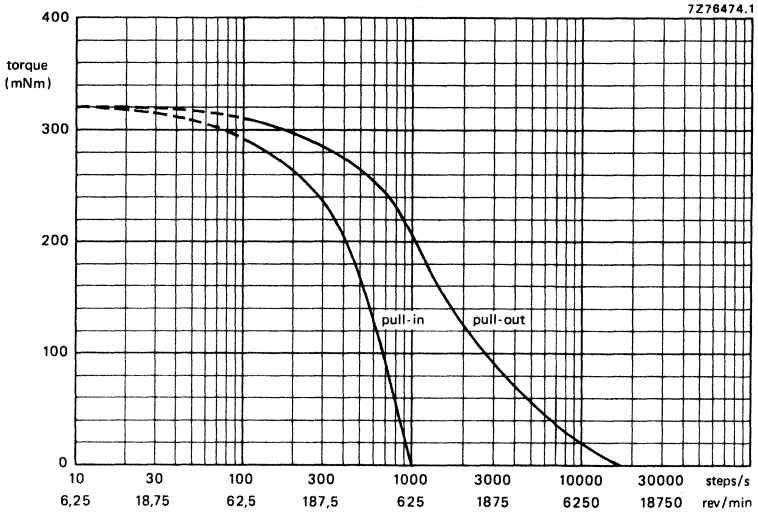

Fig. 3 Torque versus stepping rate, measured at room temperature.

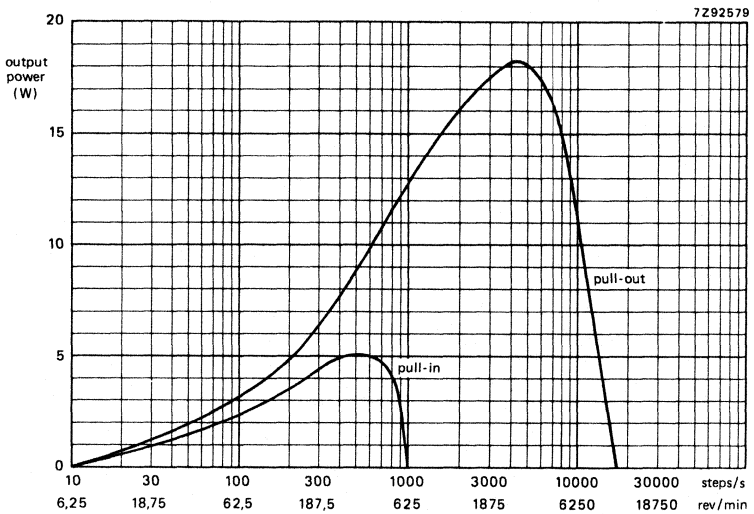

Fig. 4 Output versus stepping rate, measured at room temperature.

## 4-PHASE BIPOLAR STEPPING MOTOR

permanent magnet version

### QUICK REFERENCE DATA

Performance obtained with electronic drive unit 9904 131 03008

Step angle	7° 30'
Maximum working torque	190 mNm
Holding torque	210 mNm
Maximum pull-in rate	520 steps/s
Maximum pull-out rate	7000 steps/s

### TECHNICAL DATA

#### Outlines

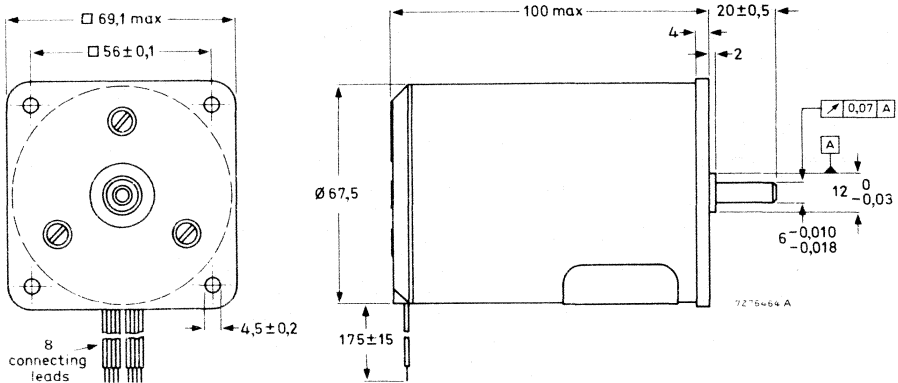

Fig. 1.

#### Connecting leads

1 = brown	1' = brown/white
2 = red	2' = red/white
3 = orange	3' = orange/white
4 = yellow	4' = yellow/white

catalogue number

9904 112 30201

Power consumption of motor only  
 Maximum working torque  
 Holding torque  
 Torque derating  
 Maximum pull-in rate  
 Maximum pull-out rate  
 Number of phases  
 Resistance per phase  
 Inductance per phase  
 Current per phase  
 Permissible ambient temperature range  
 Permissible storage temperature range  
 Permissible motor temperature  
 Insulation resistance at 500 V (CEE100)  
 Step angle  
 Step-angle tolerance, non-cumulative  
 Number of steps per revolution  
 Direction of rotation  
 Rotor inertia  
 Mass  
 Maximum radial force  
 Maximum axial force  
 Bearings, front  
                   rear

7,5 W  
 190 mNm  
 210 mNm  
 -0,4%/K  
 520 steps/s  
 7000 steps/s  
 4  
 7,5  $\Omega$   
 70 mH  
 500 mA  
 see General section of Stepping motors  
 -40 to + 100  $^{\circ}\text{C}$   
 120  $^{\circ}\text{C}$   
 > 2 M $\Omega$   
 7 $^{\circ}$  30'  
 $\pm$  30'  
 48  
 reversible  
 160 gcm<sup>2</sup>  
 1100 g  
 50 N  
 20 N  
 ball  
 slide

**Connections**

→ The connecting leads are colour-coded and are connected to the electronic drive unit 9904 112 03008 as shown in the General section of 4-phase bipolar stepping motors.

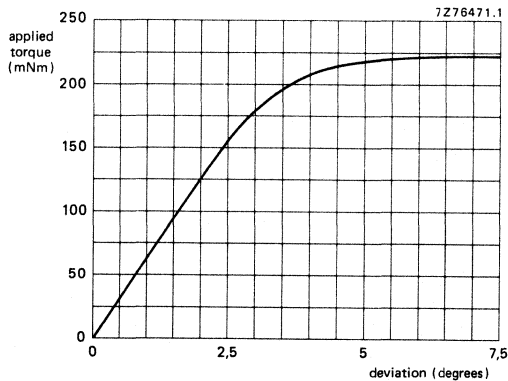

Fig. 2 Applied torque versus deviation.

Motor 9904 112 30201 with drive unit 9904 131 03008

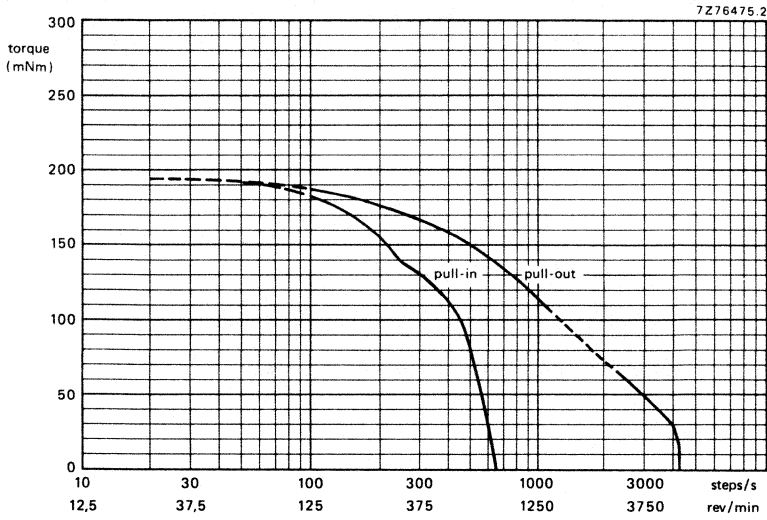

Fig. 3 Torque versus stepping rate, measured at room temperature.

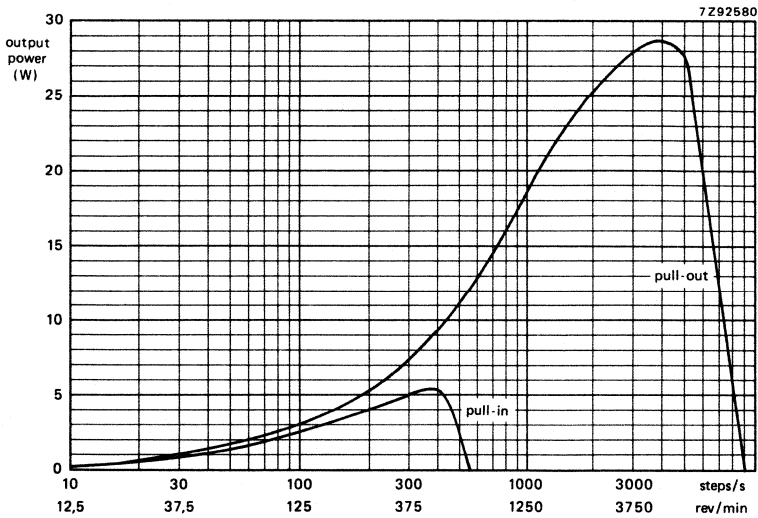

Fig. 4 Output power versus stepping rate, measured at room temperature.







catalogue number	9904 112 31001	9904 112 31101	
Power consumption of motor only	4	4	W
Maximum working torque	22	24	mNm
Holding torque	30	34	mNm
Torque derating	-0,4	-0,4	%/K
Maximum pull-in rate	180	400	steps/s
Maximum pull-out rate	—	500	steps/s
Resistance per phase at 20 °C	62	17	Ω
Inductance per phase	160	45	mH
Current per phase	190	325	mA
Thermal resistance, coil-ambient	12	12	K/W
Permissible ambient temperature range	-20 to + 70	-20 to + 70	°C
Permissible storage temperature range	-40 to + 100	-40 to + 100	°C
Permissible motor temperature	120	120	°C
Insulation resistance at 500 V (CEE 10)	> 2	> 2	MΩ
Step angle	7° 30'	7° 30'	
Step angle tolerance, not cumulative	± 20'	± 20'	
Number of steps per revolution	48	48	
Direction of rotation	reversible	reversible	
Rotor inertia	11	11	gcm <sup>2</sup>
Mass	200	200	g
Maximum radial force	5	5	N
Maximum axial force	1,5	1,5	N
Bearings	slide (bronze)	slide (bronze)	

### Connections

The connecting leads are colour-coded (see Fig. 1) and are connected to the IC or drive unit as shown in the General Section on 4-phase unipolar stepping motors.

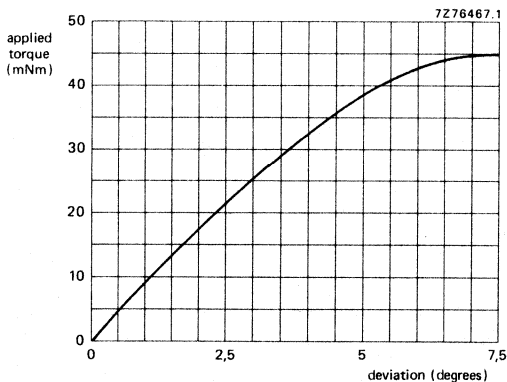

Fig. 2 Applied torque versus deviation.

Motor 9904 112 31001 with integrated circuit SAA1027

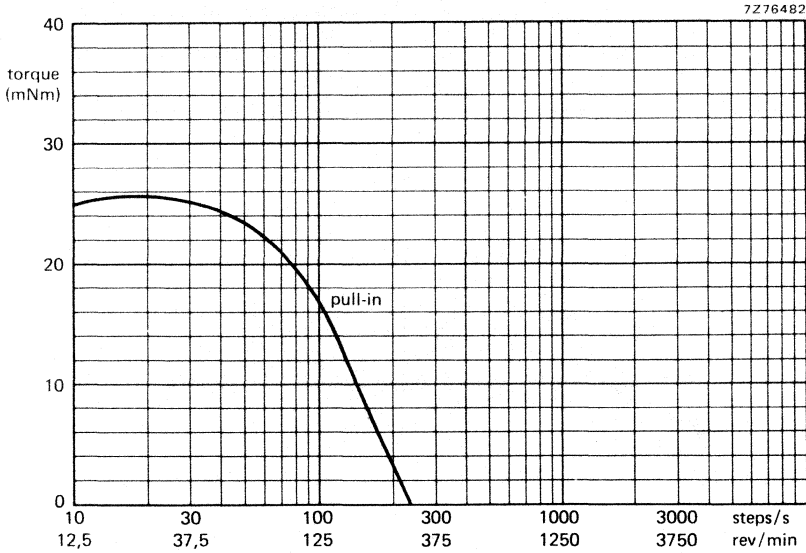

Fig. 3 Torque versus stepping rate, measured at room temperature.

Motor 9904 112 31101 with drive unit 9904 131 03006

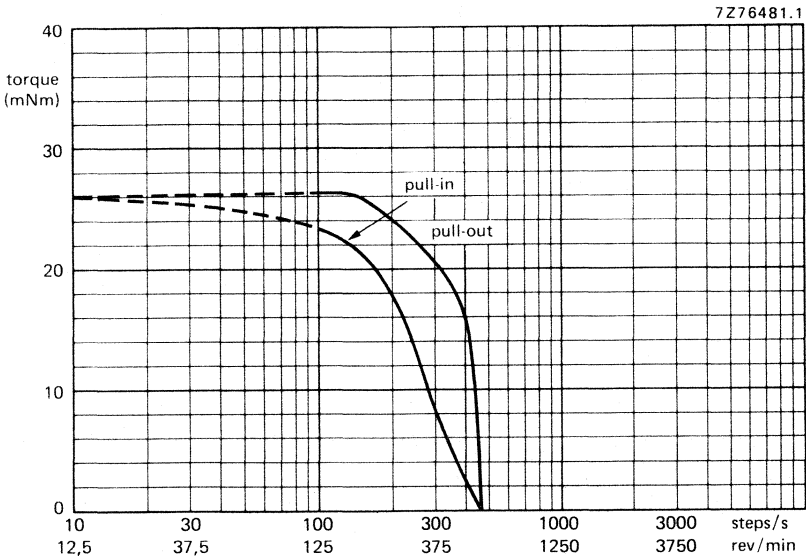

Fig. 4 Torque versus stepping rate, measured at room temperature.

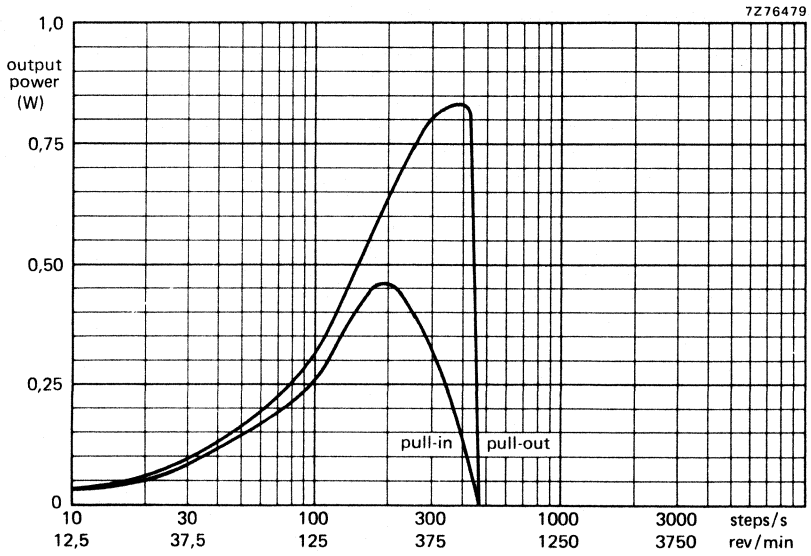

Fig. 5 Output power versus stepping rate, measured at room temperature.  
(type 9904 112 31101)

## 4-PHASE UNIPOLAR STEPPING MOTORS

permanent magnet, economy version

### QUICK REFERENCE DATA

motor type	9904 112 31004	9904 112 31104
performance obtained with	integrated circuit SAA1027	drive unit 9904 131 03006
Step angle	7° 30'	7° 30'
Max. working torque	20 mNm	24 mNm
Holding torque	28 mNm	32 mNm
Max. pull-in rate	240 steps/s	400 steps/s
Max. pull-out rate	—	500 steps/s

### APPLICATION

These motors are designed as economy versions. They have six solder tag connections for automated production.

### TECHNICAL DATA

#### Outlines

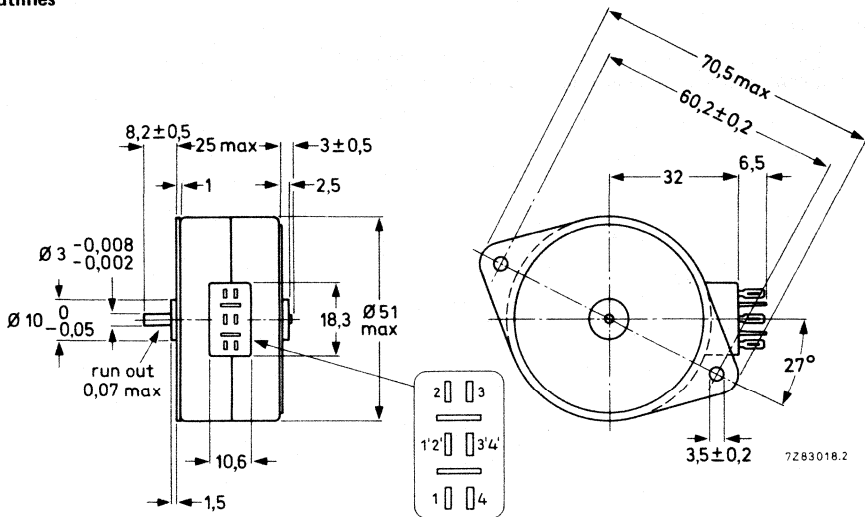

Fig. 1.

catalogue number	9904 112 31004	9904 112 31104	
Power consumption of motor only	3,8	3,5	W
→ Maximum working torque	20	24	mNm
Holding torque	28	32	mNm
Torque derating	-0,4	-0,4	%/K
Maximum pull-in rate	240	400	steps/s
Maximum pull-out rate	-	500	steps/s
Resistance per phase at 20 °C	65	11	Ω
Inductance per phase	100	16	mH
Current per phase	175	400	mA
Thermal resistance, coil-ambient	13	13	K/W
Permissible ambient temperature range	-20 to + 70	-20 to + 70	°C
Permissible storage temperature range	-40 to + 100	-40 to + 100	°C
Permissible motor temperature	120	120	°C
Insulation resistance at 500 V (CEE 10)	> 2	> 2	MΩ
Step angle	7° 30'	7° 30'	
Step angle tolerance, not cumulative	± 25'	± 25'	
Number of steps per revolution	48	48	
Direction of rotation	reversible	reversible	
Rotor inertia	11	11	gcm <sup>2</sup>
Mass	170	170	g
Maximum radial force	5	5	N
Maximum axial force	1,5	1,5	N
Bearings	slide (bronze)	slide (bronze)	

### Connections

The connecting tags are marked as shown in Fig. 1 and are connected to the IC or drive unit as shown in the General Section on 4-phase unipolar stepping motors.

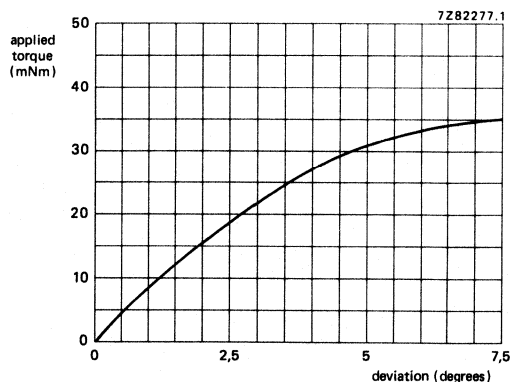

Fig. 2 Applied torque versus deviation.

Motor 9904 112 31004 with integrated circuit SAA1027

7Z82282

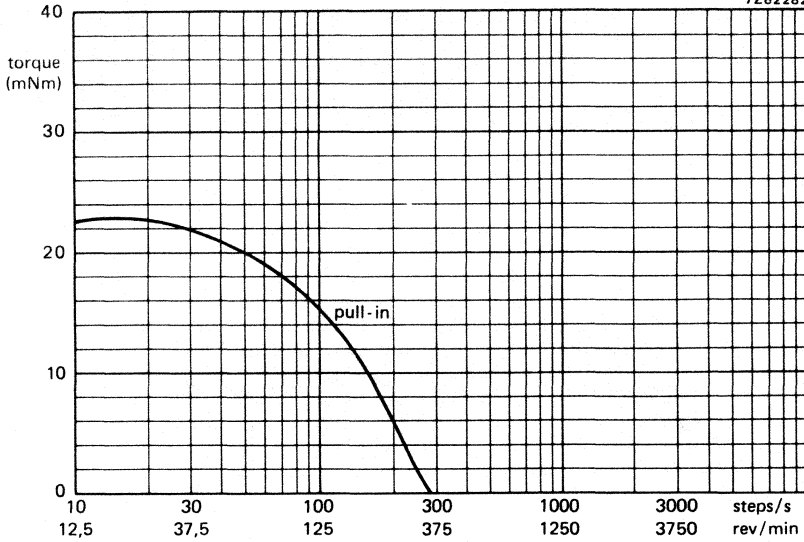

Fig. 3 Torque versus stepping rate measured at room temperature.

Motor 9904 112 31104 with drive unit 9904 131 03006

7Z82281.1

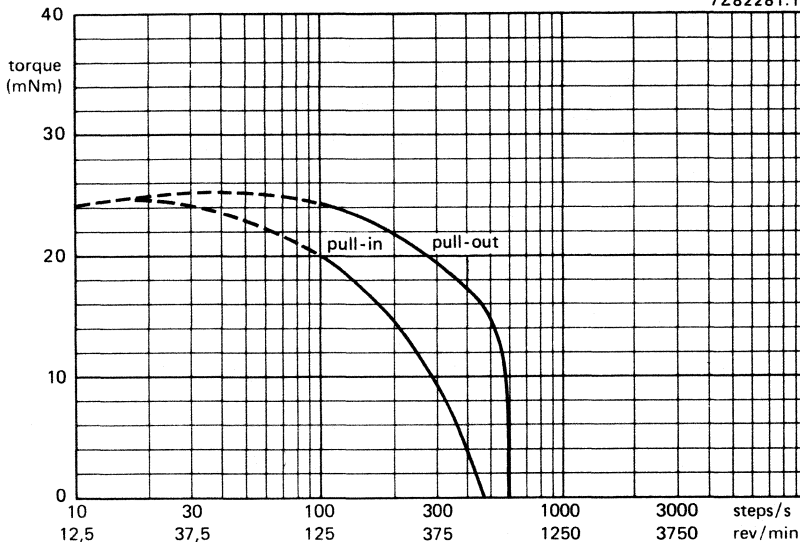

Fig. 4 Torque versus stepping rate, measured at room temperature.

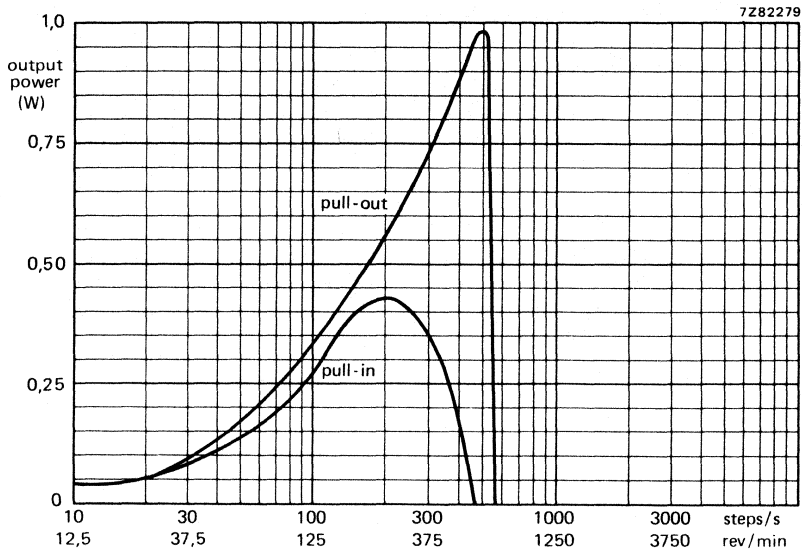

Fig. 5 Output power versus stepping rate measured at room temperature.  
(type 9904 112 31104)



## 4-PHASE UNIPOLAR STEPPING MOTORS

permanent magnet, special purpose, economy version

## QUICK REFERENCE DATA

motor type	9904 112 31006	9904 112 31106
performance obtained with	integrated circuit SAA1027	drive unit 9904 131 03006
Step angle	7° 30'	7° 30'
Max. working torque	30 mNm	33 mNm
Holding torque	42 mNm	46 mNm
Max. pull-in rate	245 steps/s	450 steps/s
Max. pull-out rate	—	620 steps/s

## APPLICATION

These motors are designed for applications where very high torque and/or high speed are required but where space is limited. Constructed on the same frame as the 9904 112 31...1 and 9904 112 31...4 motors, they deliver 40% more torque thanks to a higher magnetic flux density. Typical application areas are: paper-feed in compact printers, sewing machines, medical equipment, robotics, automobile carburettor control, etc.

## TECHNICAL DATA

## Outlines

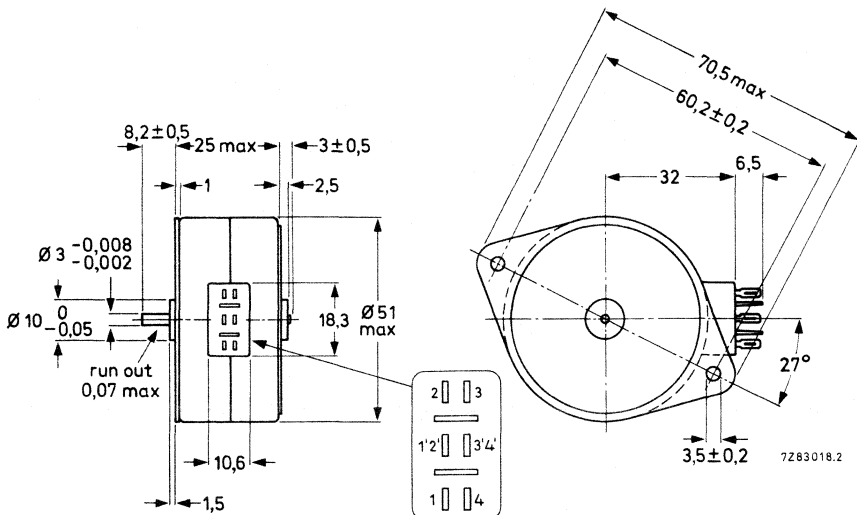

Fig. 1.

catalogue number	9904 112 31006	9904 112 31106	
Power consumption of motor only	3,8	3,5	W
Maximum working torque	30	33	mNm
Holding torque	42	46	mNm
Torque derating	-0,4	-0,4	%/K
Maximum pull-in rate	245	450	steps/s
Maximum pull-out rate	-	620	steps/s
Resistance per phase at 20 °C	65	11	Ω
Inductance per phase	100	16	mH
Current per phase	175	400	mA
Thermal resistance, coil-ambient	13	13	K/W
Permissible ambient temperature range	-20 to + 70	-20 to + 70	°C
Permissible storage temperature range	-40 to + 100	-40 to + 100	°C
Permissible motor temperature	120	120	°C
Insulation resistance at 500 V (CEE 10)	> 2	> 2	MΩ
Step angle	7° 30'	7° 30'	
Step angle tolerance, not cumulative	±25'	± 25'	
Number of steps per revolution	48	48	
Direction of rotation	reversible	reversible	
Rotor inertia	11	11	gcm <sup>2</sup>
Mass	170	170	g
Maximum radial force	5	5	N
Maximum axial force	1,5	1,5	N
Bearings	slide (bronze)	slide (bronze)	

### Connections

The connecting tags are marked as shown in Fig. 1 and are connected to the IC or drive unit as shown in the General Section on 4-phase unipolar stepping motors.

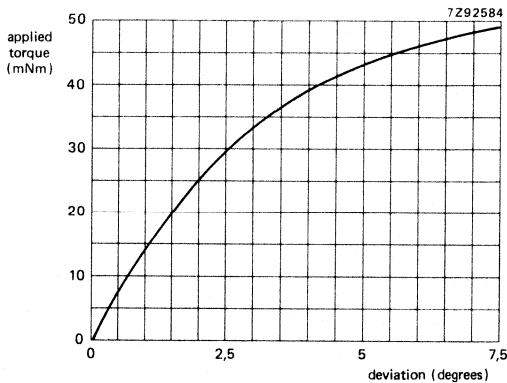

Fig. 2 Applied torque versus deviation.

Motor 9904 112 31006 with integrated circuit SAA1027

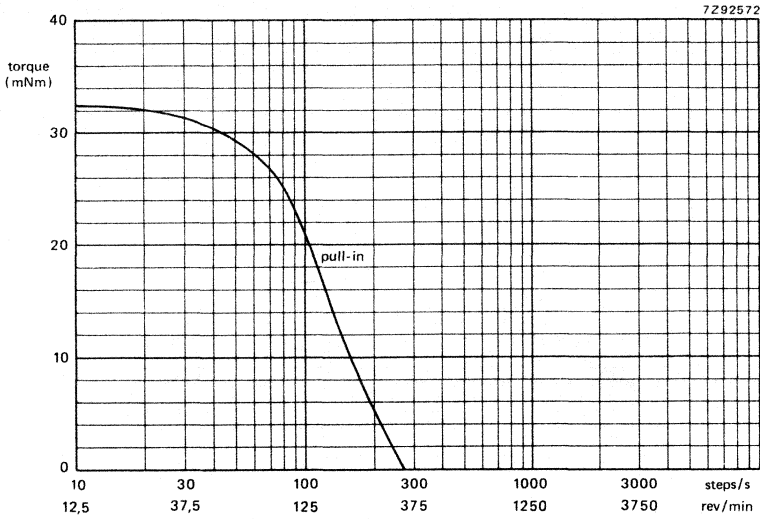

Fig. 3 Torque versus stepping rate measured at room temperature.

Motor 9904 112 31106 with drive unit 9904 121 03006

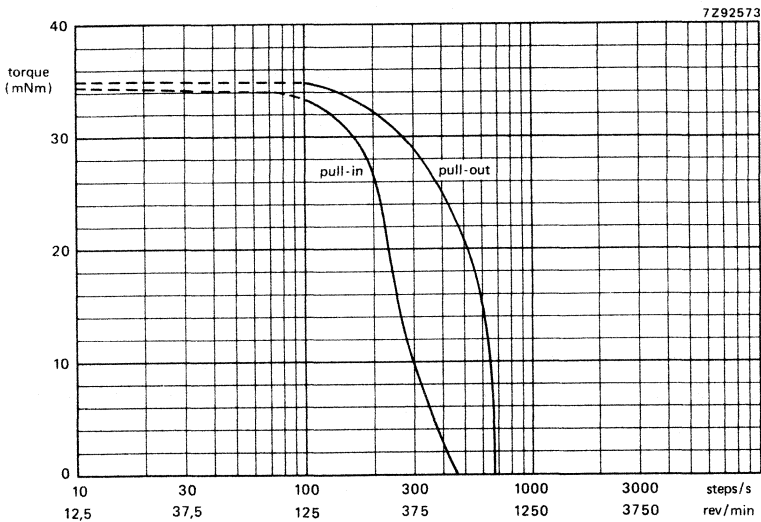

Fig. 4 Torque versus stepping rate, measured at room temperature.

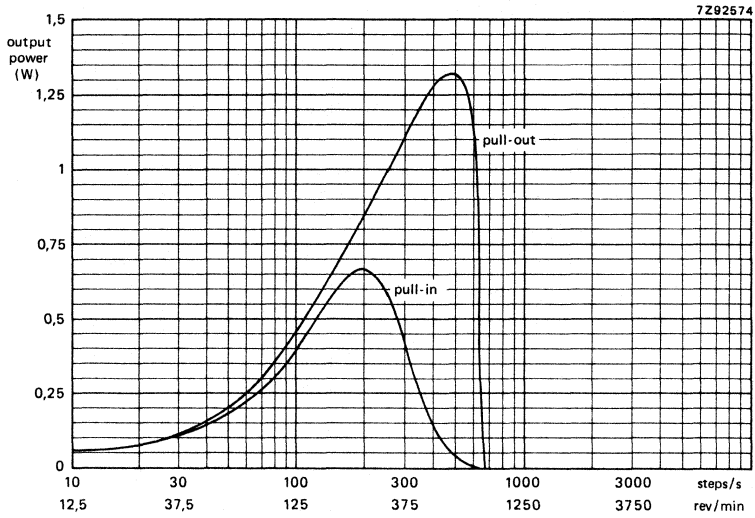

Fig. 5 Output power versus stepping rate, measured at room temperature.  
(type 9904 112 31106)



catalogue number	9904 112 31206	
Power consumption of motor only	3,5	W
Maximum working torque	45	mNm
Holding torque	55	mNm
Torque derating	-0,4	%/K
Maximum pull-in rate	620	steps/s
Maximum pull-out rate	6000	steps/s
Resistance per phase at 20 °C	7	Ω
Inductance per phase	18	mH
Current per phase	500	mA
Thermal resistance, coil-ambient	13	K/W
Permissible ambient temperature range	-20 to +70	°C
Permissible storage temperature range	-40 to +100	°C
Permissible motor temperature	120	°C
Insulation resistance at 500 V (CEE 10)	> 2	MΩ
Step angle	7° 30'	
Step angle tolerance, non-cumulative	± 25'	
Number of steps per revolution	48	
Direction of rotation	reversible	
Rotor inertia	11	gcm <sup>2</sup>
Mass	170	g
Maximum radial force	5	N
Maximum axial force *	1,5	N
Bearings	slide (bronze)	

**Connections**

The connecting tags are marked as shown in Fig. 1 and are connected to the electronic drive unit 9904 112 03007 as shown in the General Section on 2-phase bipolar stepping motors.

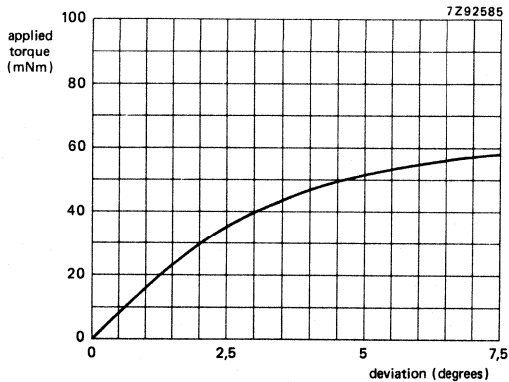

Fig. 2 Applied torque versus deviation.

\* Axial play: ≤ 0,7 mm.

Motor 9904 112 31206 with drive unit 9904 131 03007

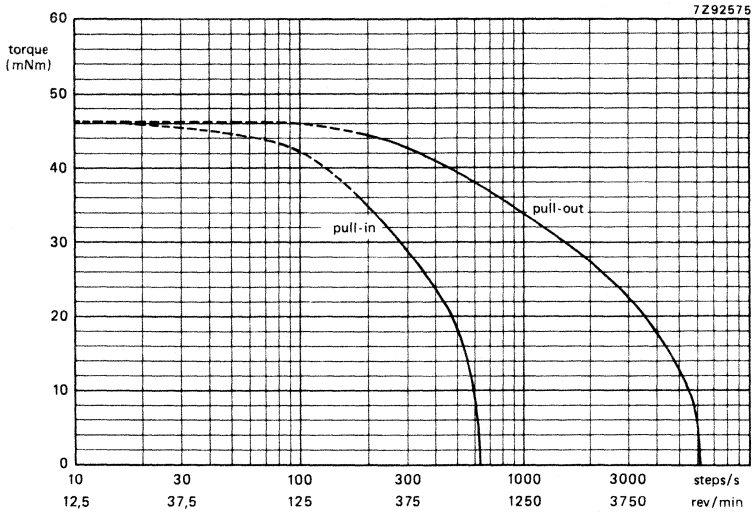

Fig. 3 Torque versus stepping rate, measured at room temperature.

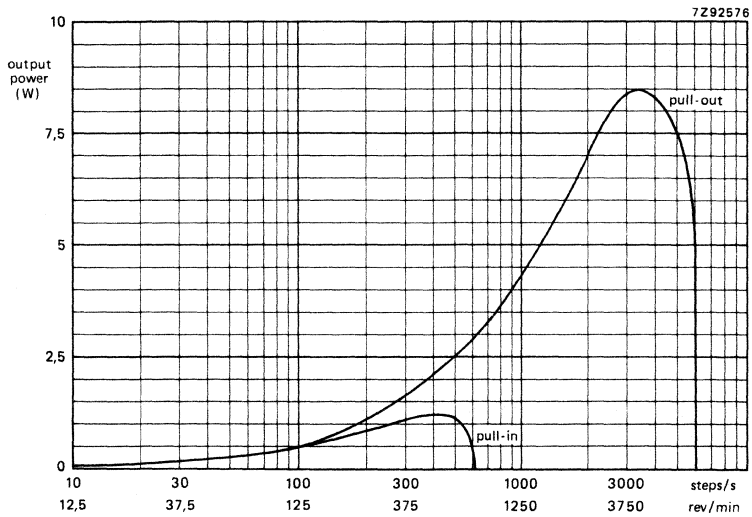

Fig. 4 Output power versus stepping rate measured at room temperature.





## 4-PHASE UNIPOLAR STEPPING MOTORS

permanent magnet version

### QUICK REFERENCE DATA

motor type	9904 112 32001	9904 112 32101
performance obtained with	integrated circuit SAA1027	drive unit 9904 131 03006
Step angle	7° 30'	7° 30'
Max. working torque	6 mNm	7,5 mNm
Holding torque	10 mNm	10 mNm
Max. pull-in rate	350 steps/s	550 steps/s
Max. pull-out rate	—	850 steps/s

### APPLICATION

Motor 9904 112 32001 is adapted for drive with IC SAA1027 and is intended for those applications where system simplicity and economy are required.

Motor 9904 112 32101 is adapted for drive unit 9904 131 03006 and is intended for those applications where variable speed in the pull-out range with higher torque are required.

Main application areas of both versions include chart recorders pen drive, butterfly drive in film projectors, paper feed in small printers, etc.

### TECHNICAL DATA

#### Outlines

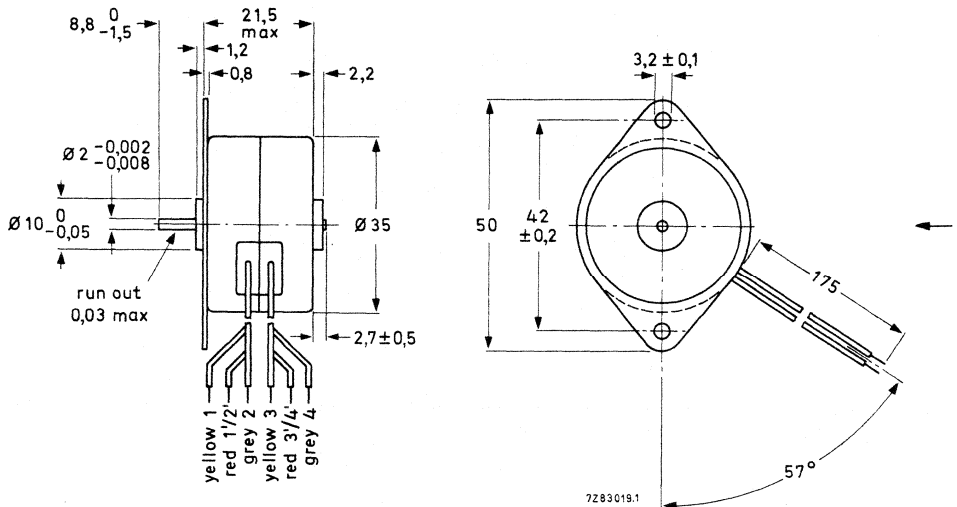

Fig. 1 The leads are double insulated (AWG24).

catalogue number	9904 112 32001	9904 112 32101	
Power consumption of motor only	2	2	W
Maximum working torque	6	7,5	mNm
Holding torque	10	10	mNm
Torque derating	-0,4	-0,4	%/K
Maximum pull-in rate	350	550	steps/s
Maximum pull-out rate	-	850	steps/s
Resistance per phase at 20 °C	120	21	Ω
Inductance per phase	160	30	mH
Current per phase	100	220	mA
Thermal resistance, coil-ambient	25	25	K/W
Permissible ambient temperature range	-20 to + 70	-20 to + 70	°C
Permissible storage temperature range	-40 to + 100	-40 to + 100	°C
Permissible motor temperature	120	120	°C
Insulation resistance at 500 V (CEE 10)	> 2	> 2	MΩ
Step angle	7° 30'	7° 30'	
Step angle tolerance, not cumulative	± 40'	± 40'	
Number of steps per revolution	48	48	
Direction of rotation	reversible	reversible	
Rotor inertia	2,6	2,6	gcm <sup>2</sup>
Mass	80	80	g
Maximum radial force	2,5	2,5	N
Maximum axial force	0,75	0,75	N
Bearings	slide (bronze)	slide (bronze)	

### Connections

The connecting leads are colour-coded (see Fig. 1) and are connected to the IC or drive unit as shown in the General Section on 4-phase unipolar stepping motors.

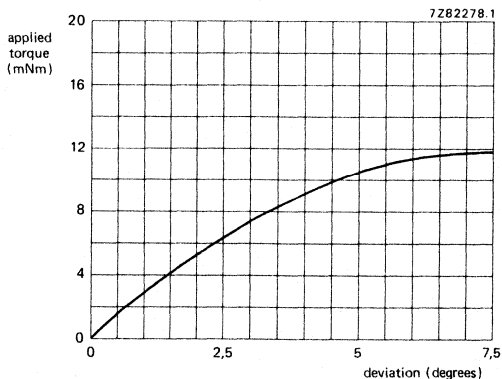

Fig. 2 Applied torque versus deviation.

Motor 9904 112 32001 with integrated circuit SAA1027

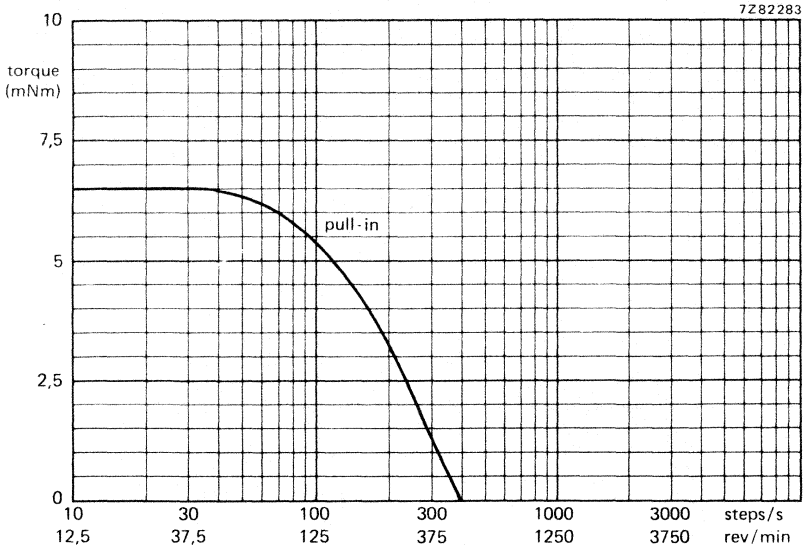

Fig. 3 Torque versus stepping rate measured at room temperature.

Motor 9904 112 32101 with drive unit 9904 131 03006

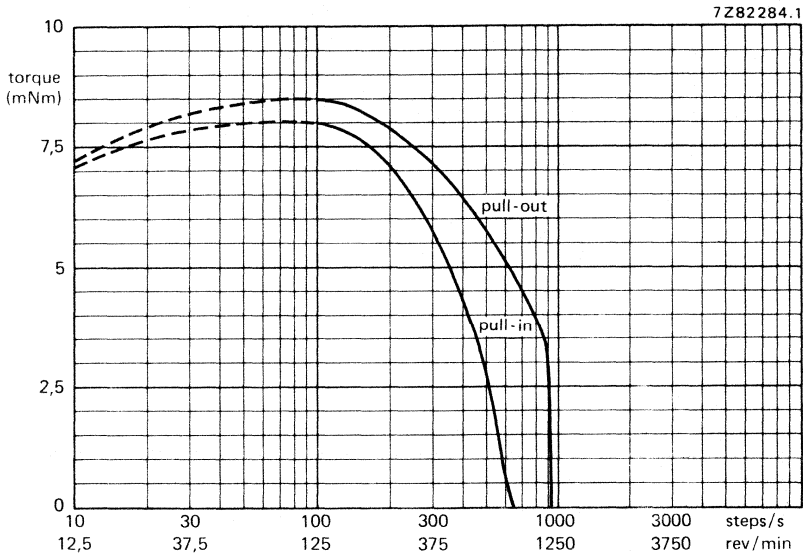

Fig. 4 Torque versus stepping rate, measured at room temperature.

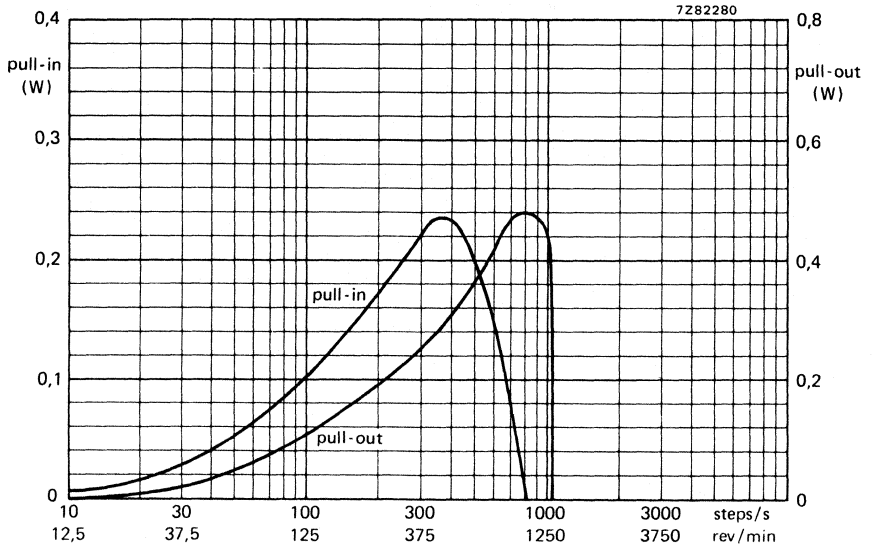

Fig. 5 Output power versus stepping rate measured at room temperature.  
(type 9904 112 32101)



catalogue number	9904 112 32204	
Power consumption of motor only	2	W
Maximum working torque	8,5	mNm
Holding torque	11,5	mNm
Torque derating	-0,4	%/K
Maximum pull-in rate	800	steps/s
Maximum pull-out rate	2500	steps/s
Resistance per phase at 20 °C	7,7	$\Omega$
Inductance per phase	16	mH
Current per phase	360	mA
Thermal resistance, coil-ambient	25	K/W
Permissible ambient temperature range	-20 to +70	°C
Permissible storage temperature range	-40 to +100	°C
Permissible motor temperature	120	°C
Insulation resistance at 500 V (CEE 10)	> 2	M $\Omega$
Step angle	7° 30'	
Step angle tolerance, non-cumulative	± 40'	
Number of steps per revolution	48	
Direction of rotation	reversible	
Rotor inertia	2,6	gcm <sup>2</sup>
Mass	70	g
Maximum radial force	2,5	N
Maximum axial force	0,75	N
Bearings	slide (bronze)	

**Connections**

The connecting tags are marked as shown in Fig. 1 and are connected to the electronic drive unit 9904 112 03007 as shown in the General Section on 2-phase bipolar stepping motors.

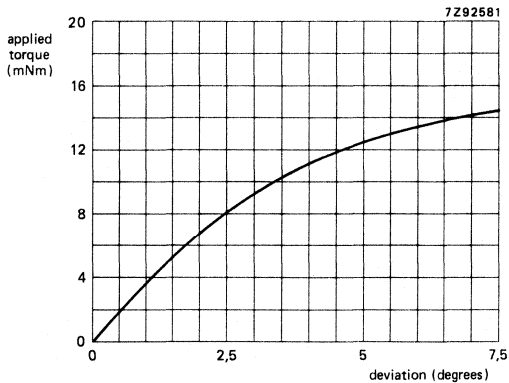

Fig. 2 Applied torque versus deviation.

Motor 9904 112 32204 with drive unit 9904 131 03007

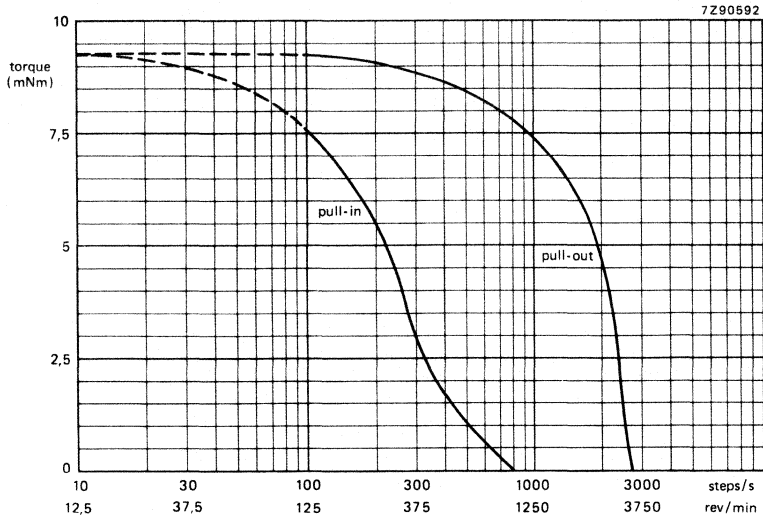

Fig. 3 Torque versus stepping rate, measured at room temperature.

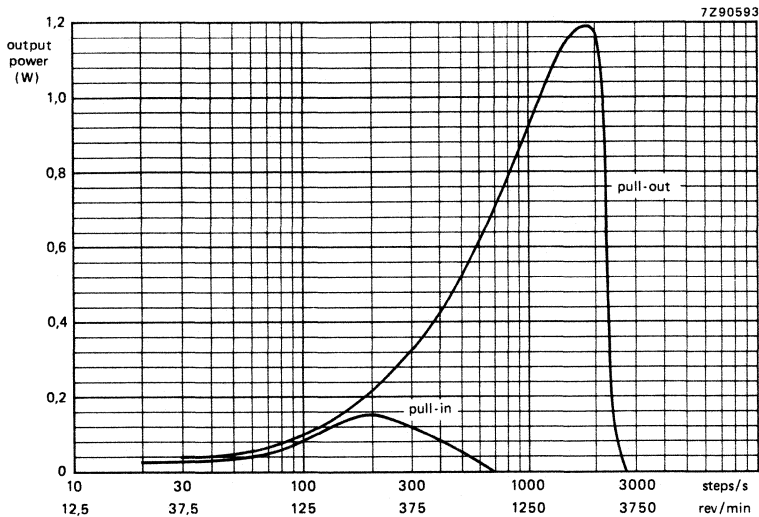

Fig. 4 Output power versus stepping rate measured at room temperature.





## 4-PHASE UNIPOLAR STEPPING MOTORS

permanent magnet version, economy version

### QUICK REFERENCE DATA

motor type	9904 112 33004	9904 112 33104
performance obtained with	integrated circuit SAA1027	drive unit 9904 131 03006 ←
Step angle	7° 30'	7° 30'
Max. working torque	90 mNm	90 mNm
Holding torque	130 mNm	130 mNm
Max. pull-in rate	100 steps/s	275 steps/s
Max. pull-out rate	—	275 steps/s

### APPLICATION

The ID33 has been designed as an economical version of the ID27. The motors of this series have no shielding can, they have one long sintered iron bearing. The coils are bifilar wound and connected to six soldering tags which protrude sideways from the motor body (permitting automated production). These motors are for applications where high torque but no high radial and/or axial force is required. Examples of application are: X-Y plotters, paper feed in printers, industrial control.

### TECHNICAL DATA

#### Outlines

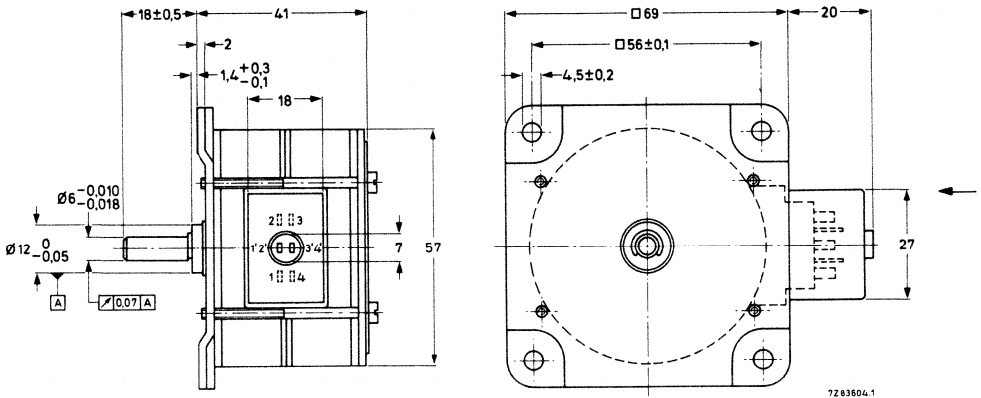

Fig. 1.

#### Note

Special versions having a spindle with a diameter of 3 mm and a length of  $8,2 \pm 0,5$  mm for use with a gearbox may be available upon request.

catalogue number	9904 112 33004	9904 112 33104	
Power consumption of motor only	7	6	W
Maximum working torque	90	90	mNm
Holding torque	130	130	mNm
Torque derating	-0,4	-0,4	%/K
Maximum pull-in rate	100	275	steps/s
Maximum pull-out rate	-	275	steps/s
Resistance per phase at 20 °C	38,5	7,8	Ω
Inductance per phase	160	35	mH
Current per phase	300	615	mA
Thermal resistance, coil-ambient	7	7	K/W
Permissible ambient temperature range	-20 to + 70	-20 to + 70	°C
Permissible storage temperature range	-40 to + 100	-40 to + 100	°C
Permissible motor temperature	120	120	°C
Insulation resistance at 500 V (CEE 10)	> 2	> 2	MΩ
Step angle	7° 30'	7° 30'	
Step angle tolerance, not cumulative	± 15'	± 15'	
Number of steps per revolution	48	48	
Direction of rotation	reversible	reversible	
Rotor inertia	80	80	gcm <sup>2</sup>
Mass	480	480	g
Maximum radial force	10	10	N
Maximum axial force	5	5	N
Bearings	one sintered iron slide	one sintered iron slide	

### Connections

The connecting tags are marked as shown in Fig. 1 and are connected to the IC or drive unit as shown in the General Section on 4-phase unipolar stepping motors.

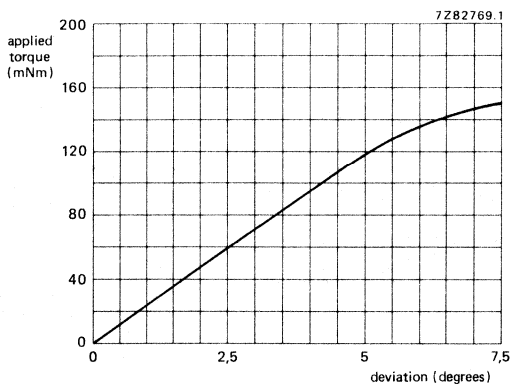

Fig. 2 Applied torque versus deviation.

Motor 9904 112 33004 with integrated circuit SAA1027

7Z82778

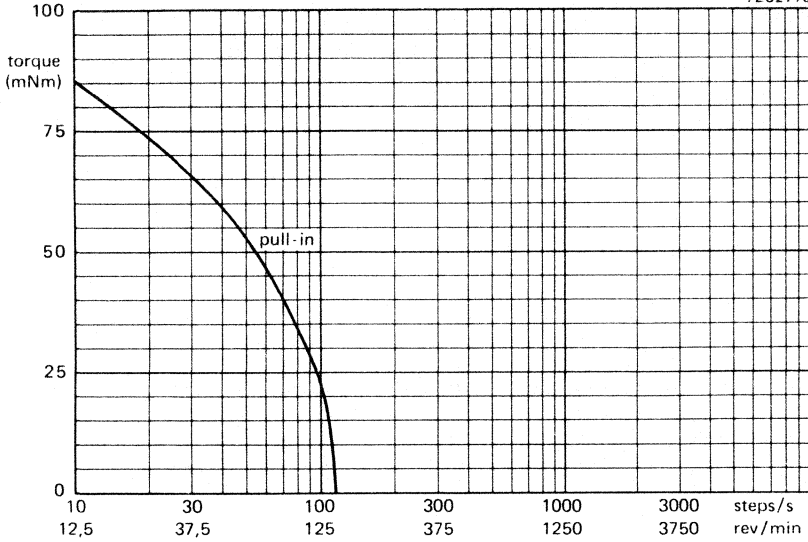

Fig. 3 Torque versus stepping rate measured at room temperature.

Motor 9904 112 33104 with drive unit 9904 131 03006

7Z82777.1

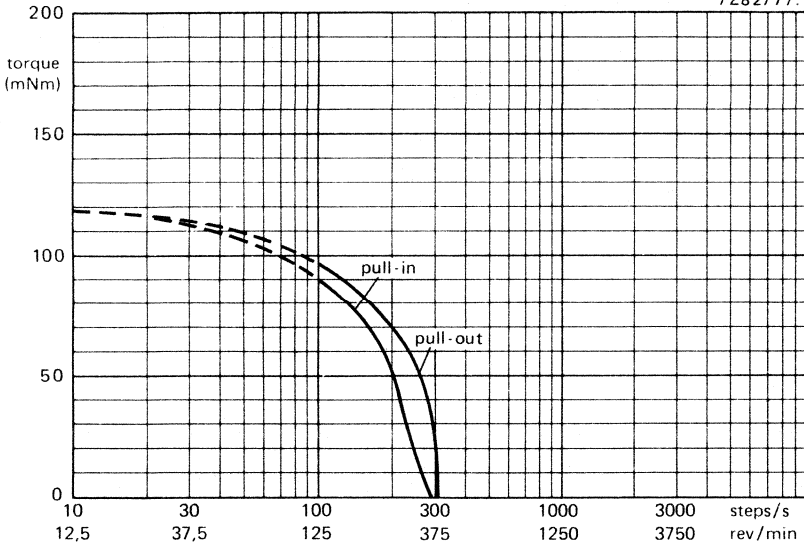

Fig. 4 Torque versus stepping rate, measured at room temperature.

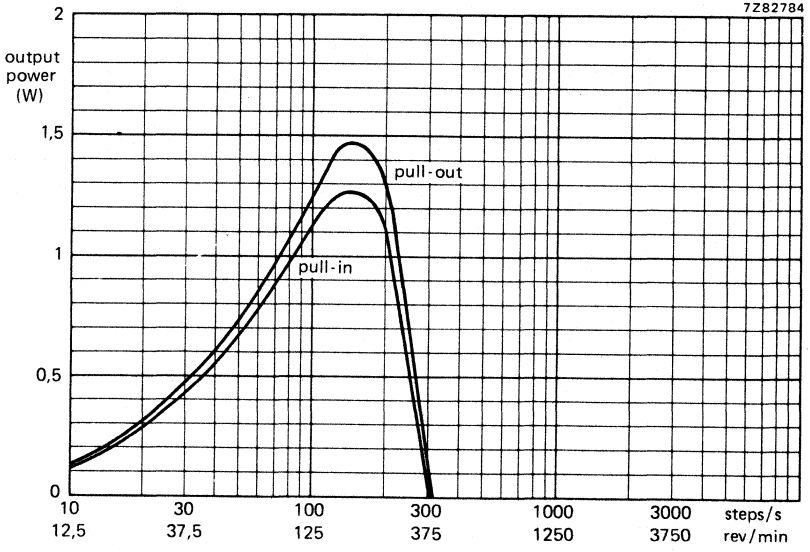

Fig. 5 Output power versus stepping rate measured at room temperature.  
(type 9904 112 33104)

## 4-PHASE UNIPOLAR STEPPING MOTORS

permanent magnet version, special purpose

### QUICK REFERENCE DATA

performance obtained with	electronic drive unit 9904 131 03006
Step angle	7° 30'
Max. working torque	110 mNm
Holding torque	150 mNm
Max. pull-in rate	275 steps/s
Max. pull-out rate	275 steps/s

### DESCRIPTION

This motor is identical to type 9904 112 33104, however a more powerful magnet is used, enabling a higher torque output.

### TECHNICAL DATA

#### Outlines

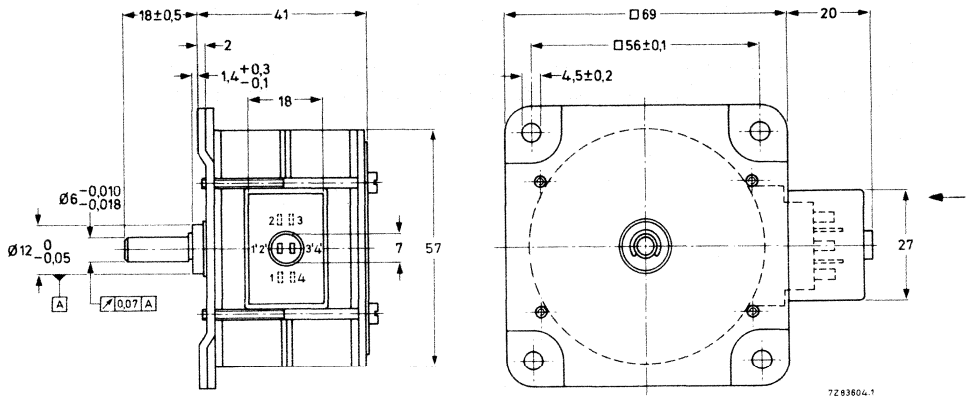

Fig. 1.

catalogue number	9904 112 33105	
Power consumption of motor only	6,5	W
Maximum working torque	110	mNm
Holding torque	150	mNm
Torque derating	-0,4	%/K
Maximum pull-in rate	275	steps/s
Maximum pull-out rate	275	steps/s
Resistance per phase at 20 °C	7,8	$\Omega$
Inductance per phase	35	mH
Current per phase	615	mA
Thermal resistance, coil-ambient	7	K/W
Permissible ambient temperature range	-20 to + 70	°C
Permissible storage temperature range	-40 to + 100	°C
Permissible motor temperature	120	°C
Insulation resistance at 500 V (CEE 10)	> 2	M $\Omega$
Step angle	7° 30'	
Step angle tolerance, not cumulative	± 15'	
Number of steps per revolution	48	
Direction of rotation	reversible	
Rotor inertia	80	gcm <sup>2</sup>
Mass	450	g
Maximum radial force	10	N
Maximum axial force	5	N
Bearings	one sintered iron slide	

**Connections**

The connecting tags are marked as shown in Fig. 1 and are connected to the electronic drive unit 9904 131 03006 as shown in the General Section on 4-phase unipolar stepping motors.

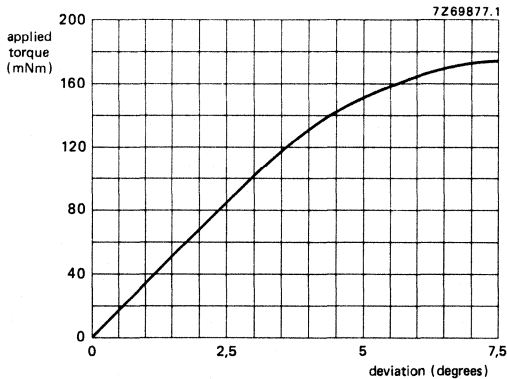

Fig. 2 Applied torque versus deviation.

Motor 9904 112 33105 with drive unit 9904 131 03006

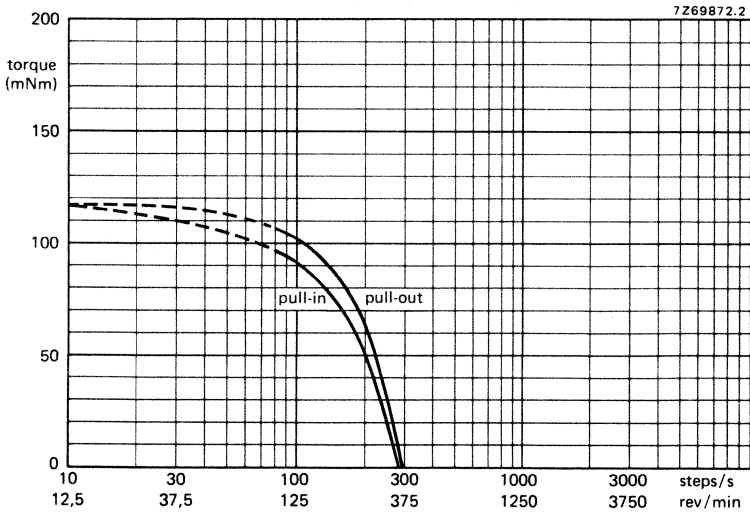

Fig. 3 Torque versus stepping rate, measured at room temperature.

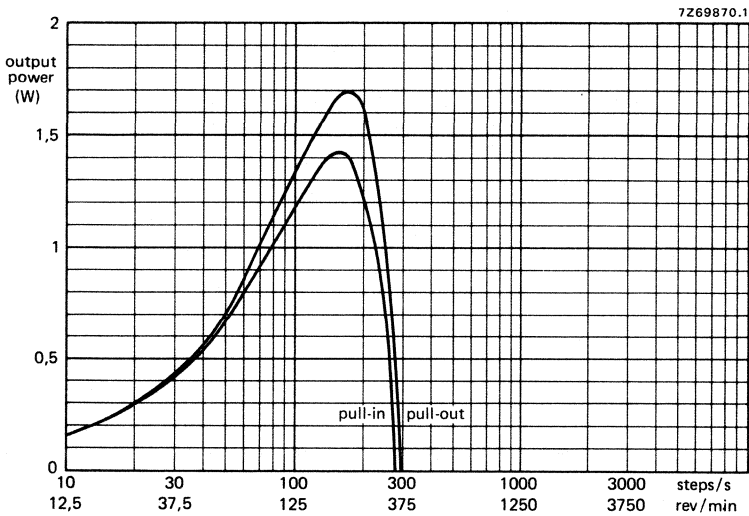

Fig. 4 Output power versus stepping rate measured at room temperature.





## 4-PHASE UNIPOLAR STEPPING MOTORS

permanent magnet version, economy version

## QUICK REFERENCE DATA

motor type	9904 112 34004	9904 112 34104
performance obtained with	integrated circuit SAA 1027	drive unit 9904 131 03006 ←
Step angle	15°	15°
Max. working torque	55 mNm	60 mNm
Holding torque	75 mNm	80 mNm
Max. pull-in rate	100 steps/s	190 steps/s
Max. pull-out rate	—	240 steps/s

## APPLICATION

The ID34 has been designed as an economical version of the ID28. The motors of this series have no shielding can, they have one long sintered iron bearing. The coils are bifilar wound and connected to six soldering tags which protrude sideways from the motor body (permitting automated production). These motors are for applications where high torque and large step angle but no high radial and/or axial force are required.

Examples of applications are: chart drive in X-Y plotters, paper feed in plotters, industrial control.

## TECHNICAL DATA

## Outlines

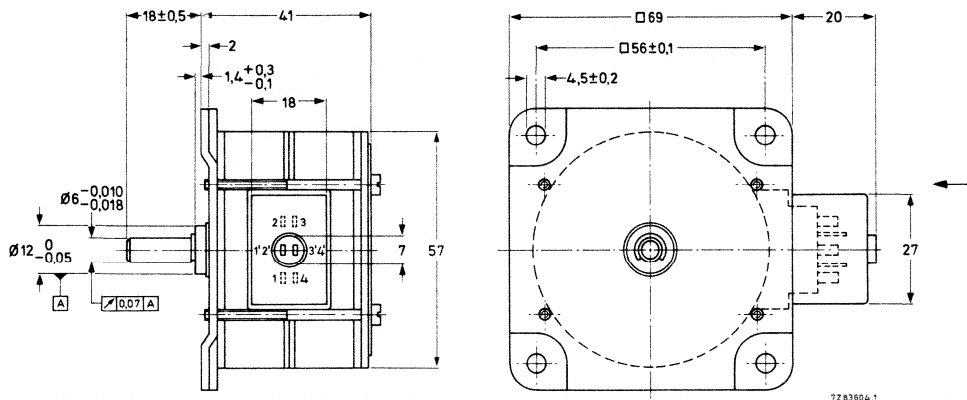

Fig. 1.

## Note

Special versions having a spindle with a diameter of 3 mm and a length of  $8,2 \pm 0,5$  mm for use with a gearbox may be available upon request.

catalogue number	9904 112 34004	9904 112 34104	
Power consumption of motor only	7	6	W
Maximum working torque	55	60	mNm
Holding torque	75	80	mNm
Torque derating	-0,4	-0,4	%/K
Maximum pull-in rate	100	190	steps/s
Maximum pull-out rate	-	240	steps/s
Resistance per phase at 20 °C	38,5	7,8	Ω
Inductance per phase	110	26	mH
Current per phase	300	615	mA
Thermal resistance, coil-ambient	7	7	K/W
Permissible ambient temperature range	-20 to + 70	-20 to + 70	°C
Permissible storage temperature range	-40 to + 100	-40 to + 100	°C
Permissible motor temperature	120	120	°C
Insulation resistance at 500 V (CEE 10)	> 2	> 2	MΩ
Step angle	15°	15°	
Step angle tolerance, not cumulative	± 30'	± 30'	
Number of steps per revolution	24	24	
Direction of rotation	reversible	reversible	
Rotor inertia	80	80	gcm <sup>2</sup>
Mass	480	480	g
Maximum radial force	10	10	N
Maximum axial force	5	5	N
Bearings	one sintered iron slide	one sintered iron slide	

### Connections

The connecting tags are marked as shown in Fig. 1 and are connected to the IC or driver unit as shown in the General Section on 4-phase unipolar stepping motors.

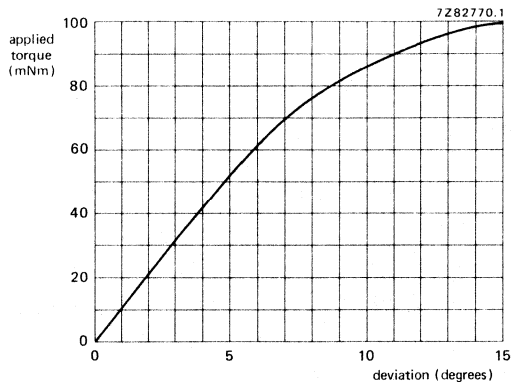

Fig. 2 Applied torque versus deviation.

Motor 9904 112 34004 with integrated circuit SAA1027

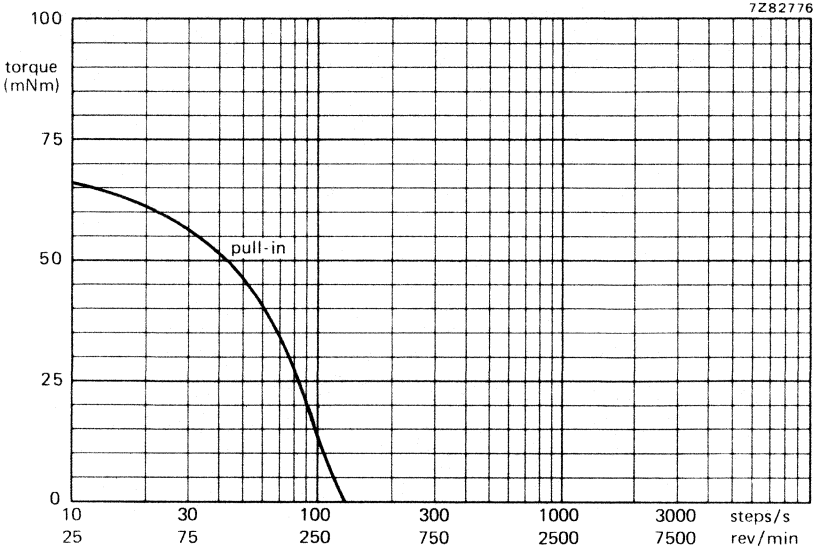

Fig. 3 Torque versus stepping rate measured at room temperature.

Motor 9904 112 34104 with drive unit 9904 131 03006

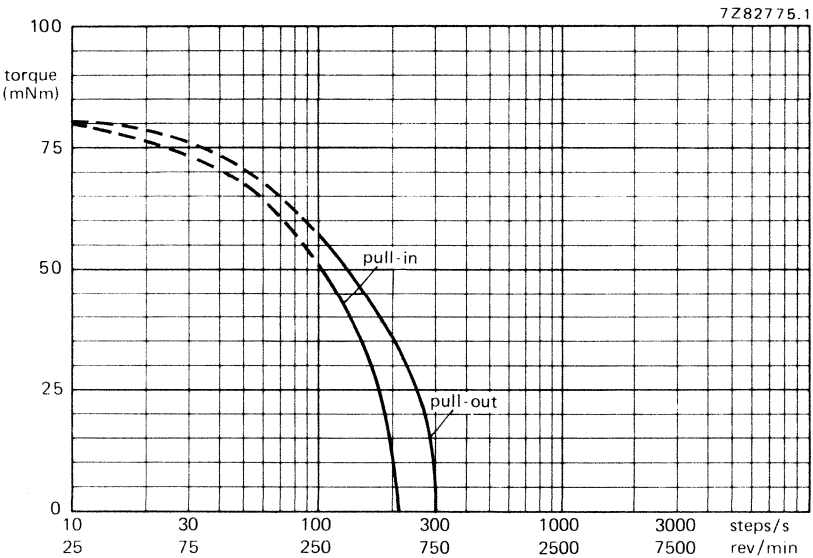

Fig. 4 Torque versus stepping rate, measured at room temperature.

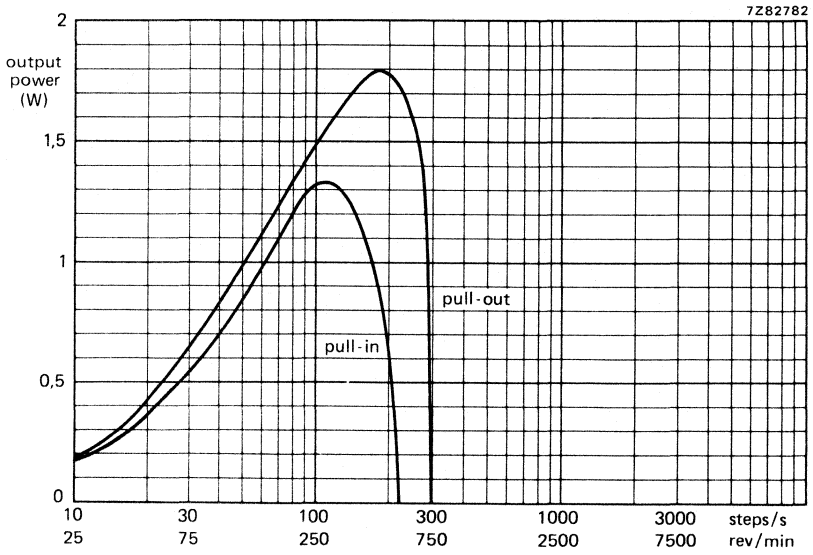

Fig. 5 Output power versus stepping rate measured at room temperature.  
(type 9904 112 34101)



catalogue number	9904 112 35014	9904 112 35114	
Power consumption of motor only	5,3	5,3	W
Maximum working torque	57	65	mNm
Holding torque	85	85	mNm
Torque derating	-0,4	-0,4	%/K
Maximum pull-in rate	130	300	steps/s
Maximum pull-out rate	-	350	steps/s
Resistance per phase at 20 °C	47	7,7	Ω
Inductance per phase	400	65	mH
Current per phase	240	575	mA
Thermal resistance, coil-ambient	10	10	K/W
Permissible ambient temp. range	-20 to +70	-20 to +70	°C
Permissible storage temp. range	-40 to +100	-40 to +100	°C
Permissible motor temperature	120	120	°C
Insulation resistance at 500 V (CEE10)	> 2	> 2	MΩ
Step angle	7° 30'	7° 30'	
Step angle tolerance, not cumulative	± 20'	± 20'	
Number of steps per revolution	48	48	
Direction of rotation	reversible	reversible	
Rotor inertia	45	45	gcm <sup>2</sup>
Mass	300	300	g
Maximum radial force	10	10	N
Maximum axial force	1,5	1,5	N
Bearings	sintered bronze slide	sintered bronze slide	

### Connections

The connecting tags are marked as shown in Fig. 1 and are connected to the IC or driver unit as shown in the General Section on 4-phase unipolar stepping motors.

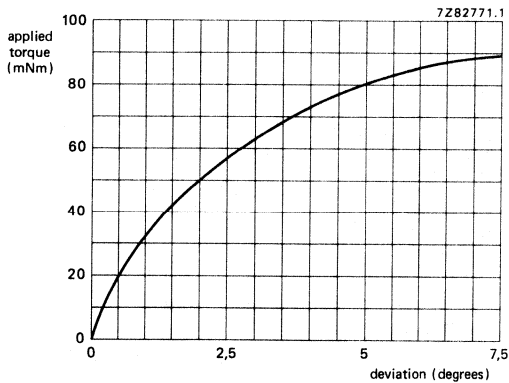

Fig. 2 Applied torque versus deviation.

Motor 9904 112 35014 with integrated circuit SAA1027

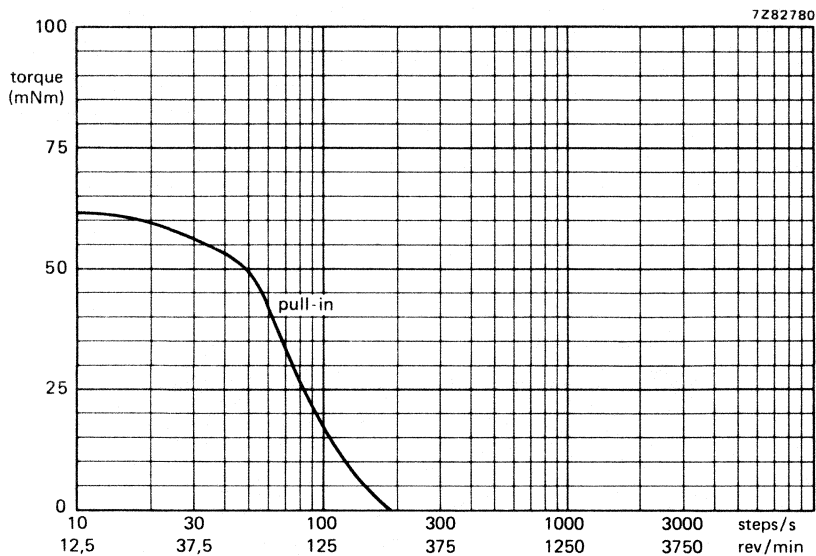

Fig. 3 Torque versus stepping rate, measured at room temperature.

Motor 9904 112 35114 with drive unit 9904 131 03006.

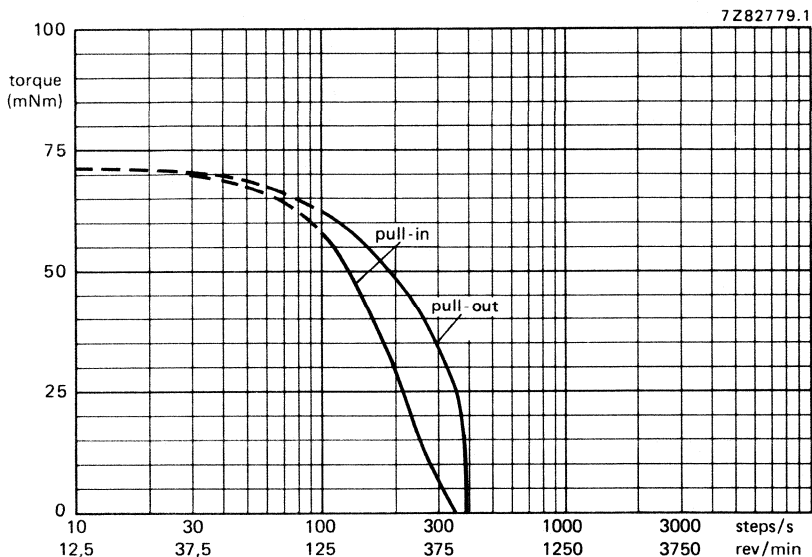

Fig. 4 Torque versus stepping rate, measured at room temperature.

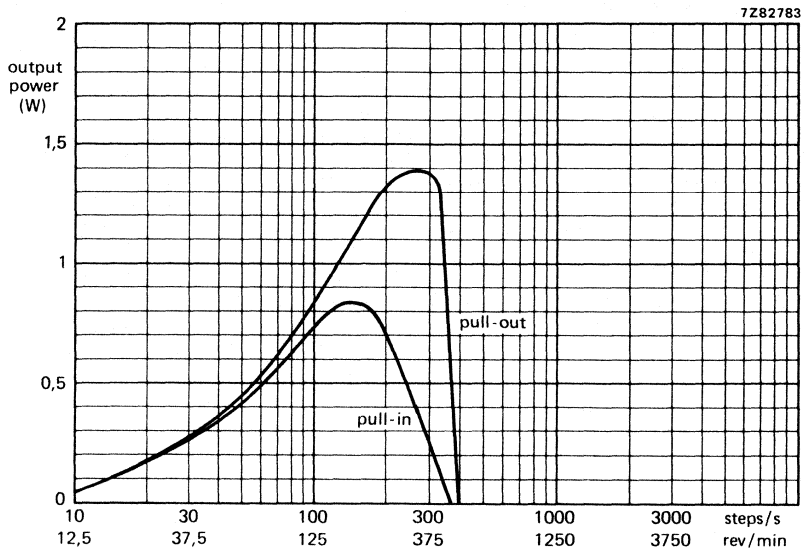

Fig. 5 Output power versus stepping rate, measured at room temperature.  
(type 9904 112 35114)



## 4-PHASE UNIPOLAR STEPPING MOTORS

permanent magnet, special purpose, economy version

## QUICK REFERENCE DATA

motor type	9904 112 35016	9904 112 35116
performance obtained with	integrated circuit SAA1027	drive unit 9904 131 03006
Step angle	7° 30'	7° 30'
Max. working torque	78 mNm	80 mNm
Holding torque	100 mNm	100 mNm
Max. pull-in rate	130 st/s	300 st/s
Max. pull-out rate	—	350 st/s

## DESCRIPTION

These motors are similar to types 9904 112 35014 and 9904 112 35114, however, with a more powerful magnet.

## TECHNICAL DATA

## Outlines

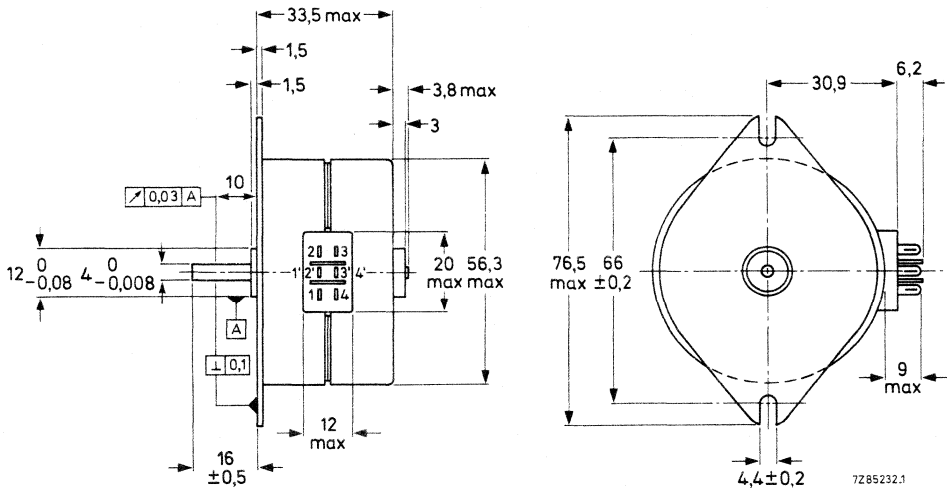

Fig. 1.

catalogue number	9904 112 35016	9904 112 35116	
Power consumption of motor only	5,3	5,3	W
Maximum working torque	78	80	mNm
Holding torque	100	100	mNm
Torque derating	-0,4	-0,4	%/K
Maximum pull-in rate	130	300	steps/s
Maximum pull-out rate	-	350	steps/s
Resistance per phase at 20 °C	47	7,7	Ω
Inductance per phase	400	65	mH
Current per phase	240	575	mA
Thermal resistance, coil-ambient	11	11	K/W
Permissible ambient temp. range	-20 to +70	-20 to +70	°C
Permissible storage temp. range	-40 to +100	-40 to +100	°C
Permissible motor temperature	120	120	°C
Insulation resistance at 500 V (CEE 10)	> 2	> 2	MΩ
Step angle	7° 30'	7° 30'	
Step angle tolerance, not cumulative	± 20'	± 20'	
Number of steps per revolution	48	48	
Direction of rotation	reversible	reversible	
Rotor inertia	45	45	gcm <sup>2</sup>
Mass	300	300	g
Maximum radial force	10	10	N
Maximum axial force	1,5	1,5	N
Bearings	sintered bronze slide	sintered bronze slide	

### Connections

The connecting tags are marked as shown in Fig. 1 and are connected to the IC or driver unit as shown in the General Section on 4-phase unipolar stepping motors.

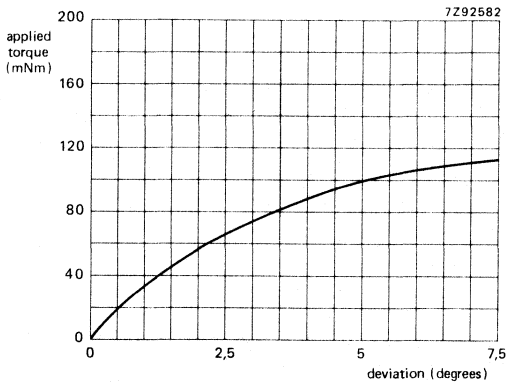

Fig. 2 Applied torque versus deviation.

Motor 9904 112 35016 with integrated circuit SAA1027

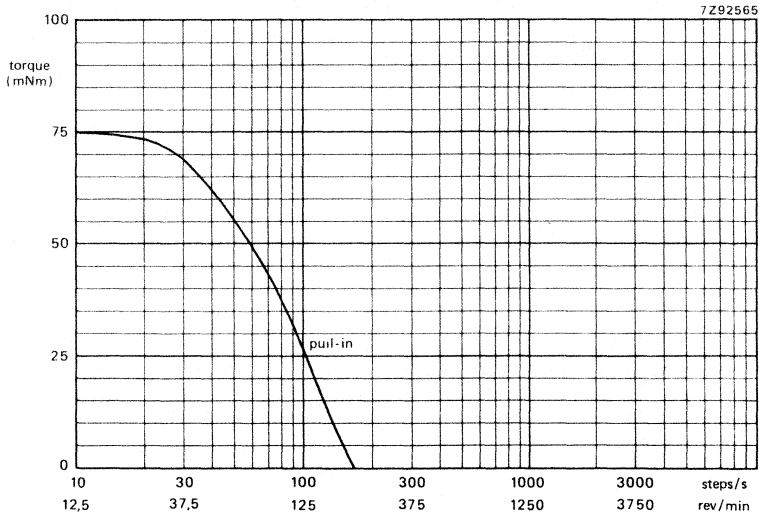

fig. 3 Torque versus stepping rate, measured at room temperature.

Motor 9904 112 35116 with drive unit 9904 131 03006

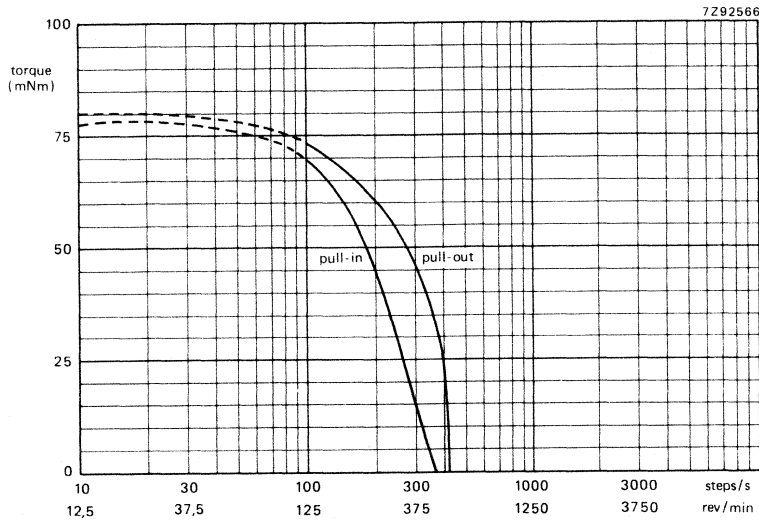

fig. 4 Torque versus stepping rate, measured at room temperature.

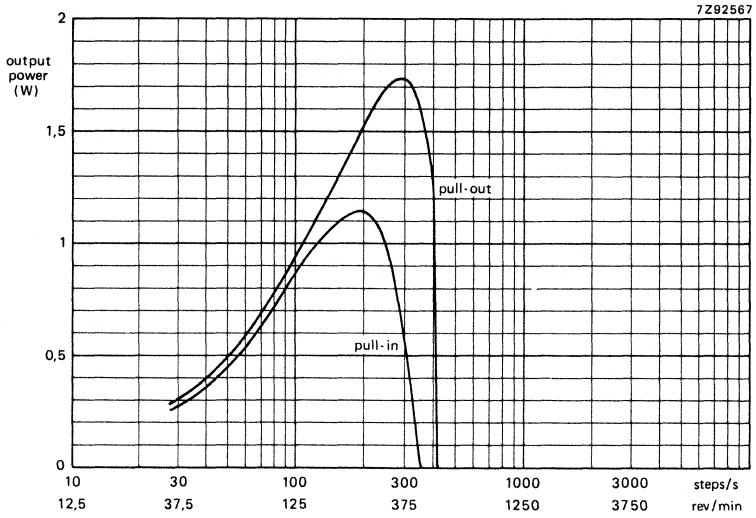

Fig. 5 Output power versus stepping rate, measured at room temperature.  
(type 9904 112 35116)



catalogue number	9904 112 35214	
Power consumption of motor only	5	W
Maximum working torque	63	mNm
Holding torque	90	mNm
Torque derating	-0,4	%/K
Maximum pull-in rate	400	steps/s
Maximum pull-out rate	1300	steps/s
Resistance per phase at 20 °C	8,5	Ω
Inductance per phase	130	mH
Current per phase	500	mA
Thermal resistance, coil-ambient	11	K/W
Permissible ambient temp. range	-20 to +70	°C
Permissible storage temp. range	-40 to +100	°C
Permissible motor temperature	120	°C
Insulation resistance at 500 V (CEE 10)	> 2	MΩ
Step angle	7° 30'	
Step angle tolerance, not cumulative	± 25'	
Number of steps per revolution	48	
Direction of rotation	reversible	
Rotor inertia	45	gcm <sup>2</sup>
Mass	300	g
Maximum radial force	10	N
Maximum axial force	1,5	N
Bearings	sintered bronze slide	

**Connections**

The connecting tags are marked as shown in Fig. 1 and are connected to the electronic drive unit 9904 131 03007 as shown in the General Section or 2-phase bipolar stepping motors.

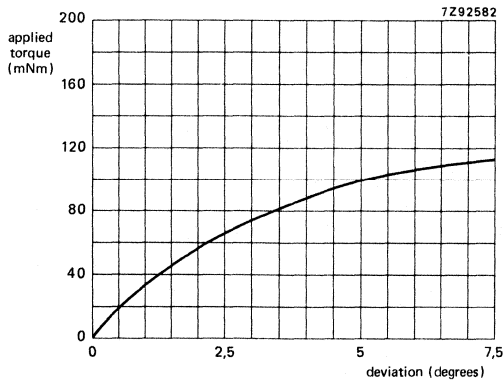

Fig. 2 Applied voltage versus deviation.

Motor 9904 112 35214 with drive unit 9904 131 03007

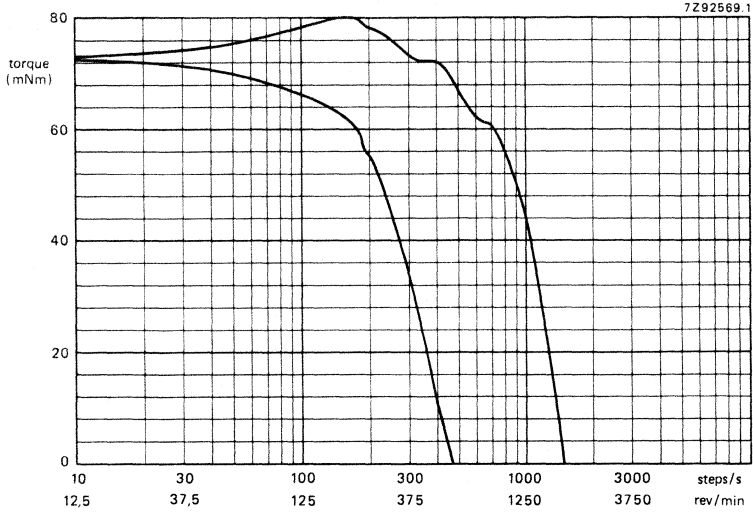

Fig. 3 Torque versus stepping rate, measured at room temperature.

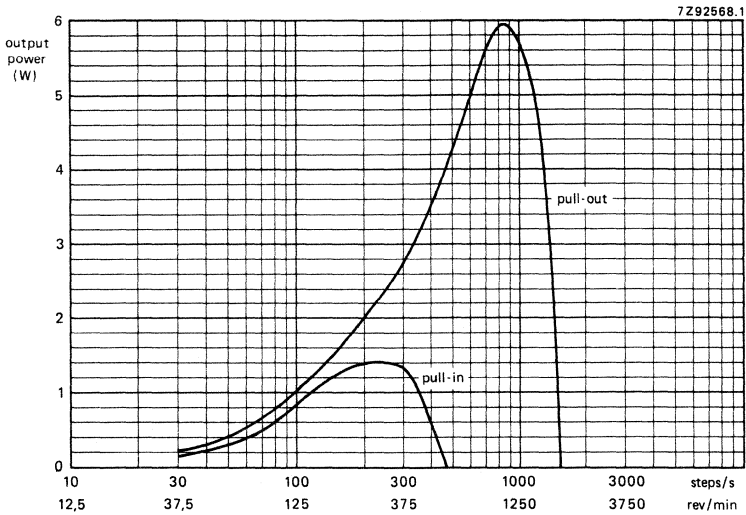

Fig. 4 Output power versus stepping rate, measured at room temperature.





## 2-PHASE BIPOLAR STEPPING MOTORS

permanent magnet, special purpose, economy version

### QUICK REFERENCE DATA

performance obtained with electronic drive unit 9904 131 03007

Step angle	7° 30'
Max. working torque	95 mNm
Holding torque	125 mNm
Max. pull-in rate	570 st/s
Max. pull-out rate	1100 st/s

### APPLICATION

This motor is for applications requiring high torque, fast acceleration and high output power in a minimum volume.

### TECHNICAL DATA

#### Outlines

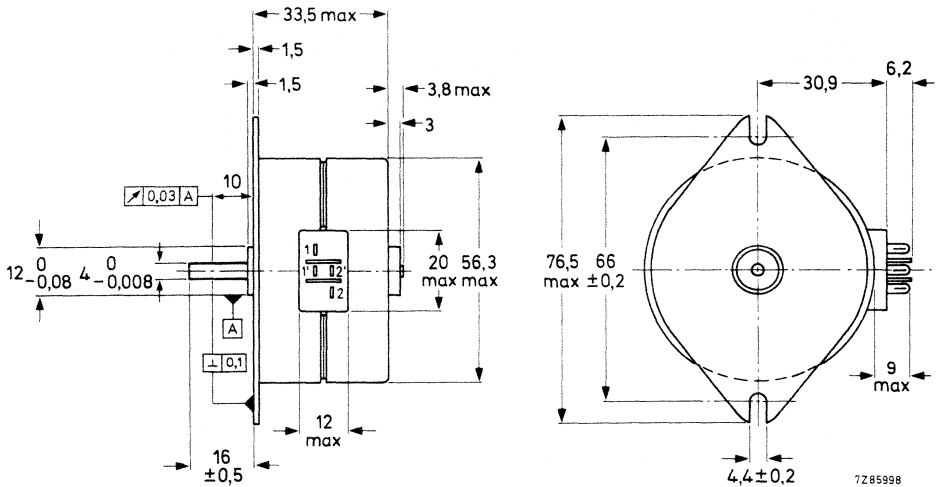

Fig. 1.

catalogue number	9904 112 35216	
Power consumption of motor only	5	W
Maximum working torque	95	mNm
Holding torque	125	mNm
Torque derating	-0,4	%/K
Maximum pull-in rate	570	steps/s
Maximum pull-out rate	1100	steps/s
Resistance per phase at 20 °C	8,5	Ω
Inductance per phase	130	mH
Current per phase	500	mA
Thermal resistance, coil-ambient	11	K/W
Permissible ambient temp. range	-20 to +70	°C
Permissible storage temp. range	-40 to +100	°C
Permissible motor temperature	120	°C
Insulation resistance at 500 V (CEE10)	> 2	MΩ
Step angle	7° 30'	
Step angle tolerance, not cumulative	± 20'	
Number of steps per revolution	48	
Direction of rotation	reversible	
Rotor inertia	45	gcm <sup>2</sup>
Mass	300	g
Maximum radial force	10	N
Maximum axial force	1,5	N
Bearings	sintered bronze slide	

**Connections**

The connecting tags are marked as shown in Fig. 1 and are connected to the electronic drive unit 9904 131 03007 as shown in the General Section on 2-phase bipolar stepping motors.

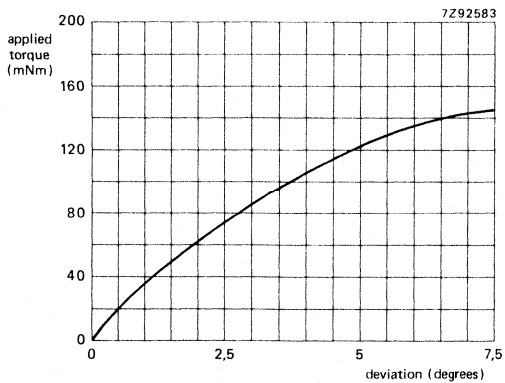

Fig. 2 Applied torque versus deviation.

Motor 9904 112 35216 with drive unit 9904 131 03007

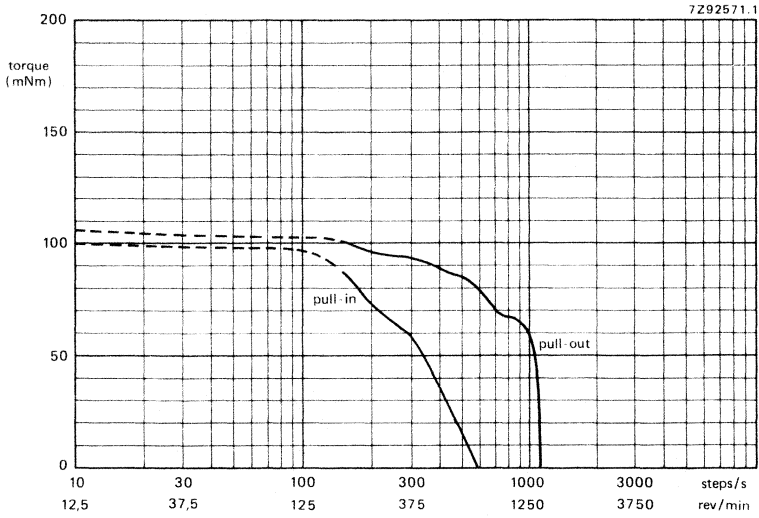

Fig. 3 Torque versus stepping rate, measured at room temperature.

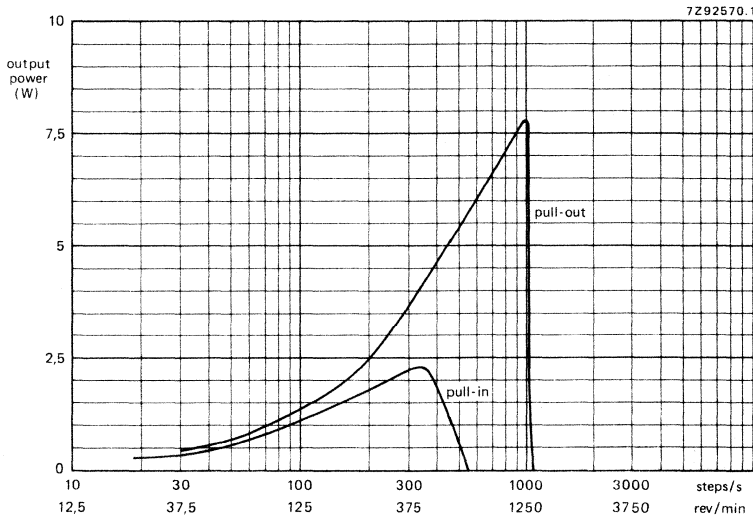

Fig. 4 Output power versus stepping rate, measured at room temperature.





catalogue number	9904 112 36014	9904 112 36114	
Power consumption of motor only	5,3	5,3	W
Maximum working torque	32	37	mNm
Holding torque	60	60	mNm
Torque derating	-0,4	-0,4	%/K
Maximum pull-in rate	110	200	steps/s
Maximum pull-out rate	-	350	steps/s
Resistance per phase at 20 °C	47	7,7	Ω
Inductance per phase	170	27	mH
Current per phase	240	575	mA
Thermal resistance, coil-ambient	10	10	K/W
Permissible ambient temp. range	-20 to + 70	-20 to + 70	°C
Permissible storage temp. range	-40 to + 100	-40 to + 100	°C
Permissible motor temperature	120	120	°C
Insulation resistance at 500 V (CEE 10)	> 2	> 2	MΩ
Step angle	15°	15°	
Step angle tolerance, not cumulative	± 30'	± 30'	
Number of steps per revolution	24	48	
Direction of rotation	reversible	reversible	
Rotor inertia	45	45	gcm <sup>2</sup>
Mass	300	300	g
Maximum radial force	10	10	N
Maximum axial force	1,5	1,5	N
Bearings	sintered bronze slide	sintered bronze slide	

### Connections

The connecting tags are marked as shown in Fig. 1 and are connected to the IC or driver unit as shown in the General Section on 4-phase unipolar stepping motors.

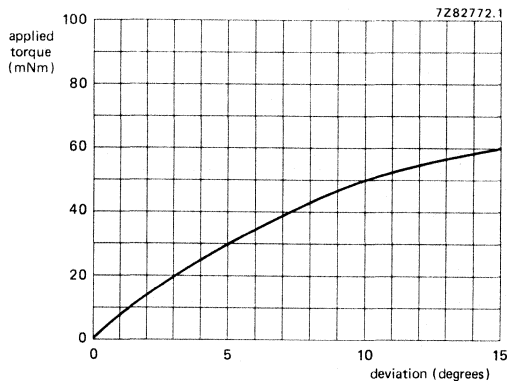

Fig. 2 Applied torque versus deviation.

Motor 9904 112 36014 with integrated circuit SAA1027

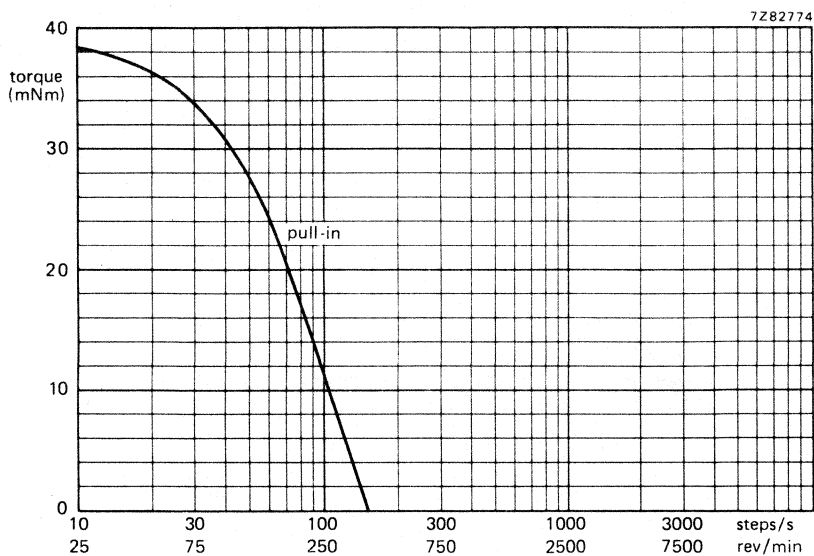

Fig. 3 Torque versus stepping rate, measured at room temperature.

Motor 9904 112 36114 with drive unit 9904 131 03006

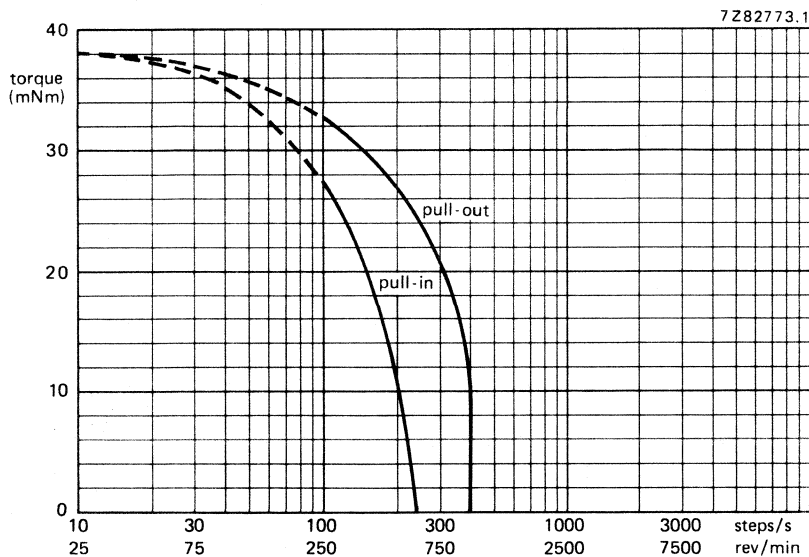

Fig. 4 Torque versus stepping rate, measured at room temperature.

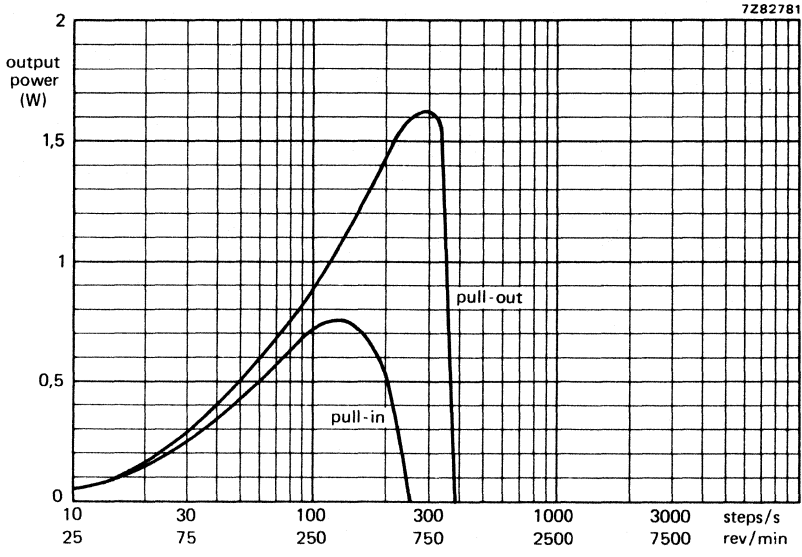

Fig. 5 Output power versus stepping rate, measured at room temperature.  
(type 9904 112 36114)



# DEVELOPMENT DATA

This data sheet contains advance information and specifications are subject to change without notice.

HR15

9904 115 15101

## 4-PHASE UNIPOLAR HYBRID STEPPING MOTOR

### QUICK REFERENCE DATA

---

#### Performance obtained with unipolar drive unit 9904 131 03006

---

Step angle	1,8 degrees
Maximum working torque	45 mNm
Holding torque	55 mNm
Maximum pull-in rate	675 Hz
Maximum pull-out rate	750 Hz

---

### APPLICATION

- floppy disc head positioning
- paper feed in mini printers and electronic typewriters
- positioning in X-Y recorders
- instrumentation: e.g. dosing pumps
- automotive actuators, e.g. in carburettors

### DESCRIPTION

This hybrid stepping motor is equipped with unipolar ring coils and soft iron stator and rotor. A steel magnet is used in the rotor.

Precision ball bearings are used, limiting the spindle wobble to max. 15  $\mu\text{m}$ .

TECHNICAL DATA

Outlines

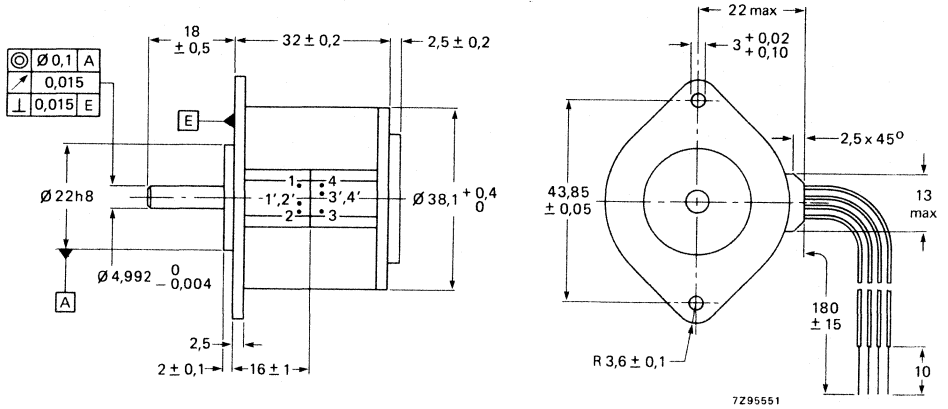

Fig. 1.

Connecting leads

- 1 = yellow
- 1', 2' = red
- 2 = grey
- 3 = white/yellow
- 3', 4' = white/red
- 4 = white/grey

Catalogue number	9904 115 15101	
Power supply ( $V_b$ )	12	V
Power consumption of motor only	3,6	W
Maximum working torque (10 Hz)	45	mNm
Torque derating	0,4	%/K
Holding torque	55	mNm
Maximum pull-in rate (note 1)	675	Hz
Maximum pull-out rate (note 1)	750	Hz
Resistance per phase (at 20 °C)	75	$\Omega$
Inductance per phase (1000 Hz)	22	mH
Current per phase	160	mA
Thermal resistance, coil-ambient	10	K/W
Permissible ambient temperature range	-20 to + 70	°C
Permissible storage temperature range	-40 to + 100	°C
Permissible motor temperature	130	°C
Insulation	CEE 10, class III	
Insulation resistance at 500 V d.c.	$\geq 2$	M $\Omega$
Step angle	1,8	degrees
Step angle tolerance (non cumulative)	$\pm 5$	%
Number of steps per revolution	200	
Direction of rotation	reversible	
Rotor inertia	21	gcm <sup>2</sup>
Bearings	ball	
Mass	200	g
Maximum radial force	25	N
Maximum axial force, continuously (note 2)	10	N

DEVELOPMENT DATA

Connections of the motor, see Fig. 2.  
The leads are double insulated, AWG24.

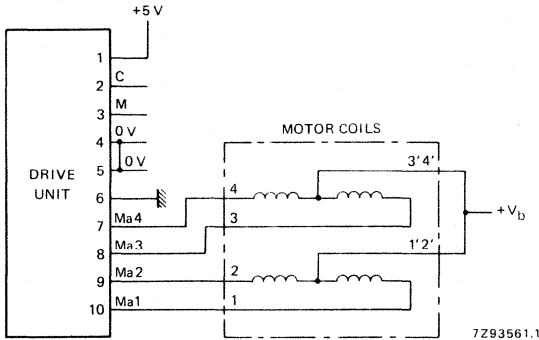

Fig. 2 Unipolar drive circuit 9904 131 03006,  $V_b = 12$  V.

**Notes**

1. Measured using unipolar constant current drive unit 9904 131 03006.
2. For pressing a pulley or pinion to the spindle. Spindle end must be supported.

Motor 9904 115 15101 with drive unit 9904 131 03006

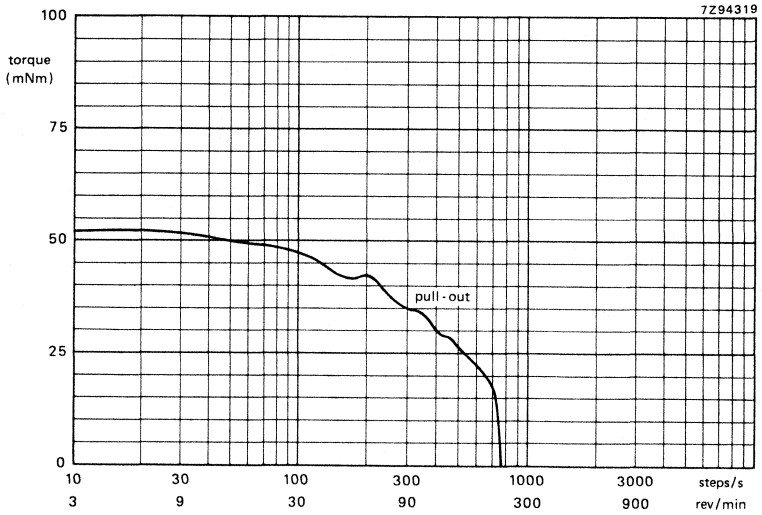

Fig. 3 Typical curve if the pull-out torque versus stepping rate measured at room temperature in the circuit of Fig. 2.

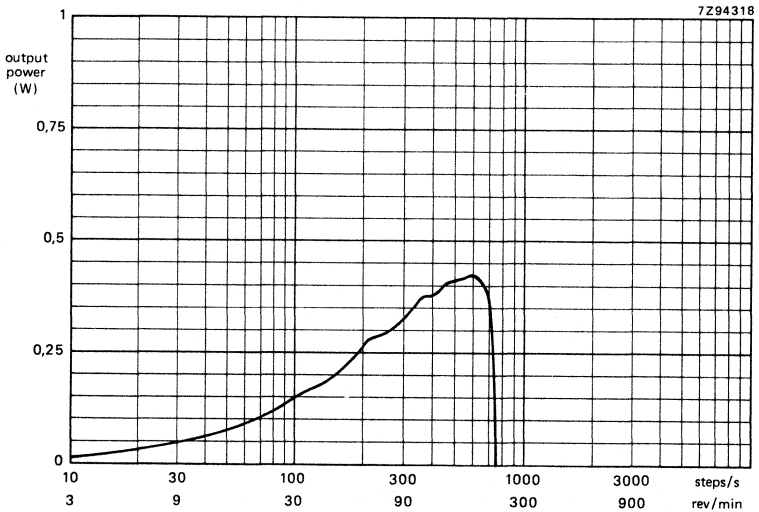

Fig. 4 Output power versus stepping rate, measured at room temperature.

# DEVELOPMENT DATA

This data sheet contains advance information and specifications are subject to change without notice.

HR15

9904 115 15201

## 2-PHASE BIPOLAR HYBRID STEPPING MOTOR

### QUICK REFERENCE DATA

---

Performance obtained with bipolar constant current drive unit 9904 131 03007

---

Step angle	1,8 degrees
Maximum working torque	45 mNm
Holding torque	60 mNm
Maximum pull-in rate	1000 Hz
Maximum pull-out rate	1500 Hz

---

### APPLICATION

- floppy disc head positioning
- winchester drive head positioning
- paper feed in mini printers and electronic typewriters
- electronic card readers
- head positioning in X-Y recorders
- instrumentation, e.g. dosing pumps
- electronic domestic appliances, e.g. sewing machines
- automotive actuator, e.g. in carburettors

### DESCRIPTION

This hybrid stepping motor is equipped with bipolar ring coils and soft iron stator and rotor. A steel magnet is used in the rotor.

Precision ball bearings are used, limiting the spindle wobble to max. 15  $\mu\text{m}$ .

TECHNICAL DATA

Outlines

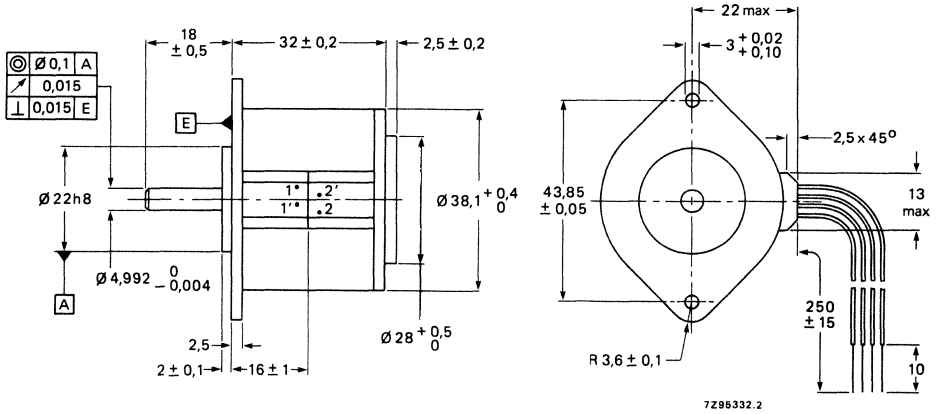

Fig. 1.

Connecting leads

- 1 = blue
- 1' = black
- 2 = red
- 2' = grey

Catalogue number	9904 115 15201	
Power supply ( $V_{MM}$ )	40	V
Power consumption of motor only	2,4	W
Maximum working torque (10 Hz)	50	mNm
Torque derating	0,1	%/K
Holding torque	60	mNm
Maximum pull-in rate (note 1)	1000	Hz
Maximum pull-out rate (note 1)	1500	Hz
Resistance per phase (at 20 °C)	37	$\Omega$
Inductance per phase (1000 Hz)	21	mH
Current per phase	180	mA
Thermal resistance, coil-ambient	10	K/W
Permissible ambient temperature range	-20 to + 60	°C
Permissible storage temperature range	-40 to + 100	°C
Permissible motor temperature	130	°C
Insulation	CEE 10, class III	
Insulation resistance at 500 V d.c.	$\geq 2$	M $\Omega$
Step angle	1,8	degrees
Step angle tolerance (non-cumulative)	$\pm 5$	%
Number of steps per revolution	200	
Direction of rotation	reversible	
Rotor inertia	21	gcm <sup>2</sup>
Bearings	ball	
Mass	200	g
Maximum radial force	25	N
Maximum axial force, continuously (note 2)	10	N

Connections of the motor, see Fig. 2.  
The leads are double-insulated, AWG24.

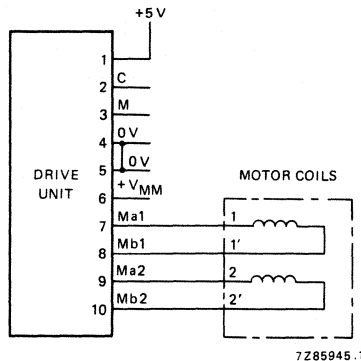

Fig. 2 Bipolar constant current drive circuit 9904 131 03007,  $V_{MM} = 40$  V.

**Notes**

1. Measured using bipolar constant current drive unit 9904 131 03007.
2. For pressing a pulley or pinion to the spindle. Spindle end must be supported.

Motor 9904 115 15201 with drive unit 9904 131 03007

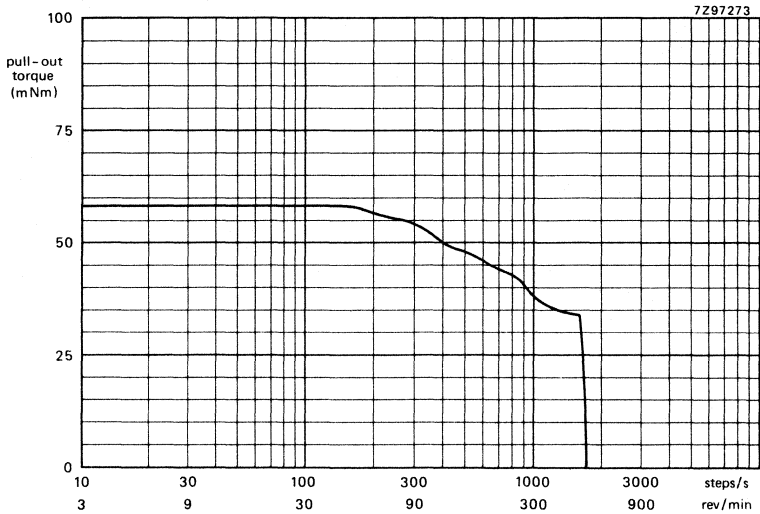

Fig. 3 Typical curve of the pull-out torque versus stepping rate measured at room temperature in the circuit of Fig. 2.

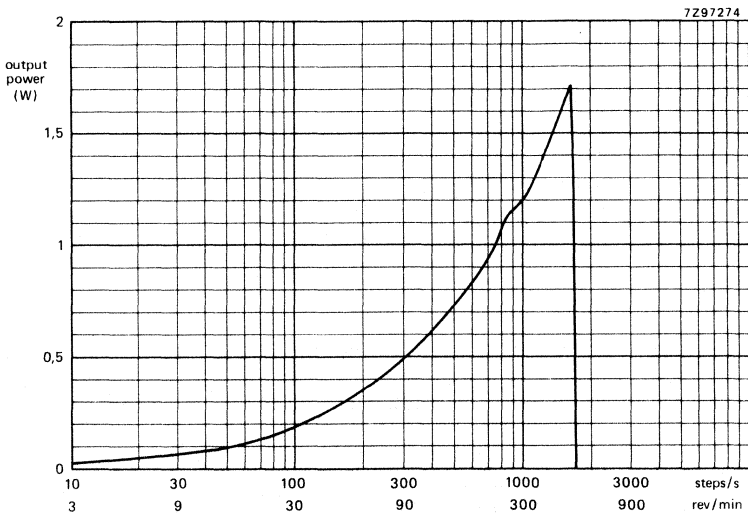

Fig. 4 Output power versus stepping rate, measured at room temperature.



# DEVELOPMENT DATA

This data sheet contains advance information and specifications are subject to change without notice.

HR15

9904 115 15401

## 2-PHASE BIPOLAR HYBRID STEPPING MOTOR

### QUICK REFERENCE DATA

Performance obtained with bipolar constant current drive unit 9904 131 03007

Step angle	1,8 degrees
Maximum working torque	45 mNm
Holding torque	60 mNm
Maximum pull-in rate	1000 Hz
Maximum pull-out rate	1500 Hz

### APPLICATION

- floppy disc head positioning
- winchester drive head positioning
- paper feed in mini printers and electronic typewriters
- electronic card readers
- head positioning in X-Y recorders
- instrumentation, e.g. dosing pumps
- electronic domestic appliances

### DESCRIPTION

This hybrid stepping motor is equipped with bipolar ring coils and soft iron stator and rotor. A steel magnet is used in the rotor.

Precision ball bearings are used, limiting the spindle wobble to max. 15  $\mu\text{m}$ .

TECHNICAL DATA

Dimensions in mm

Outlines

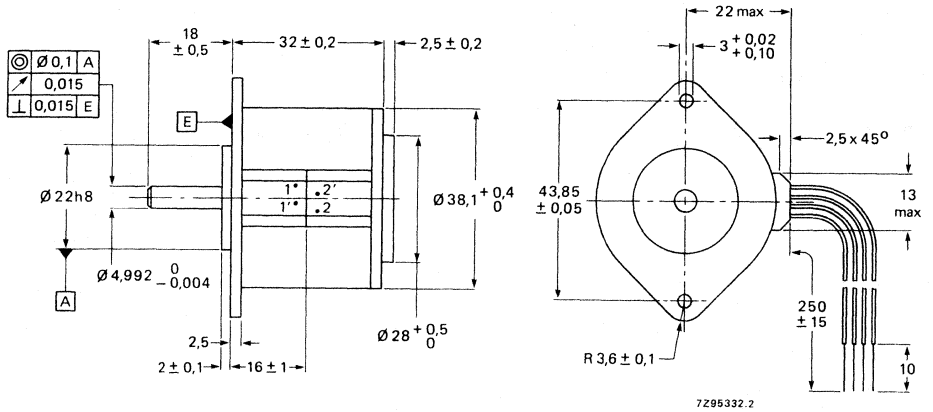

Fig. 1.

Leads, AWG26.

- 1 = blue
- 1' = black
- 2 = red
- 2' = grey

Catalogue number	9904 115 15401	
Power supply ( $V_{MM}$ )	24	V
Power consumption of motor only	2,45	W
Maximum working torque (10 Hz)	50	mNm
Holding torque	60	mNm
Maximum pull-in rate (note 1)	1000	Hz
Maximum pull-out rate (note 1)	1500	Hz
Resistance per phase (at 20 °C)	18	$\Omega$
Inductance per phase (1000 Hz)	9,5	mH
Current per phase	260	mA
Thermal resistance, coil-ambient	10	K/W
Permissible ambient temperature range	-20 to + 60	$^{\circ}$ C
Permissible storage temperature range	-40 to + 100	$^{\circ}$ C
Permissible motor temperature	130	$^{\circ}$ C
Insulation	CEE10, class III	
Insulation resistance at 500 V d.c.	$\geq 2$	M $\Omega$
Step angle	1,8	degrees
Step angle tolerance (non-cumulative)	$\pm 5$	%
Number of steps per revolution	200	
Direction of rotation	reversible	
Rotor inertia	21	gcm <sup>2</sup>
Bearings	ball	
Mass	200	g
Maximum radial force	25	N
Maximum axial force, continuously (note 2)	10	N

DEVELOPMENT DATA

Connections of the motor, see Fig. 2.  
The leads are double-insulated, AWG24.

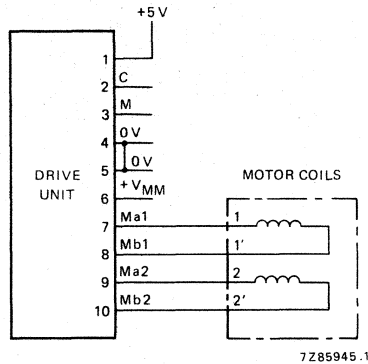

Fig. 2 Bipolar constant current drive circuit 9904 131 03007,  $V_{mm} = 24$  V.

**Notes**

1. Measured using bipolar constant current drive unit 9904 131 03007.
2. For pressing a pulley or pinion to the spindle. Spindle end must be supported.

Motor 9904 115 15401 with drive unit 9904 131 03007

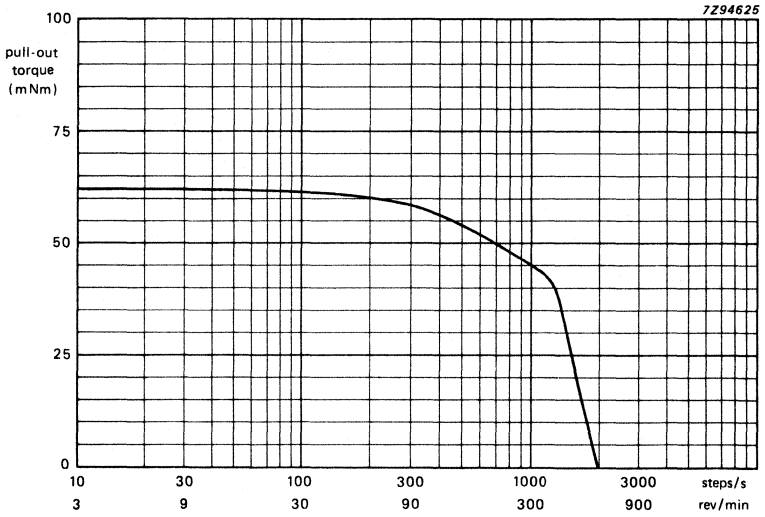

Fig. 3 Typical curve of the pull-out torque versus stepping rate measured at room temperature in the circuit of Fig. 2.

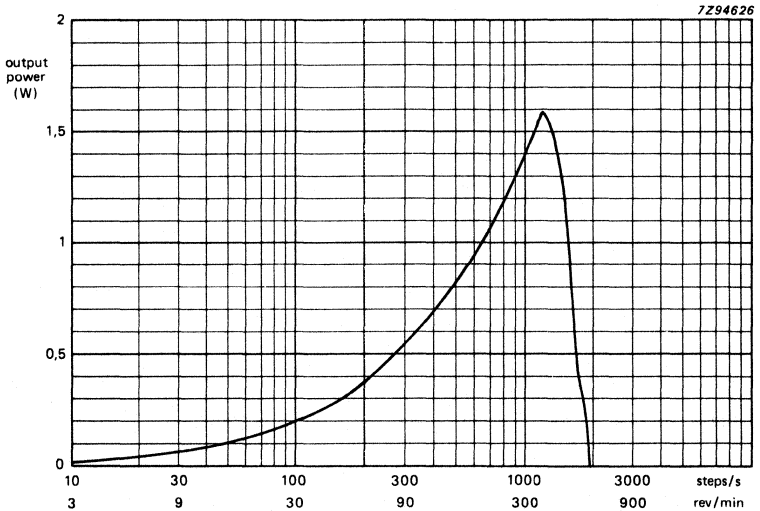

Fig. 4 Output power versus stepping rate, measured at room temperature.

## 4-PHASE UNIPOLAR HYBRID STEPPING MOTOR

### QUICK REFERENCE DATA

	unipolar	bipolar	
Performance obtained with unipolar constant current drive	9904 131 03006	03007	
Step angle	1,8	1,8	degrees
Maximum working torque	340	320	mNm
Holding torque	450	450	mNm
Maximum pull-in rate	300	600	steps/s
Maximum pull-out rate (with damped rotor)	400(4000)	850(7000)	steps/s

### APPLICATION

These motors are for applications which require high resolution, such as:

- paper feed and positioning in electronic data processing equipment, X-Y recorders and facsimile
- Winchester drive head positioning
- medical equipment, e.g. infusion pumps.

### DESCRIPTION

The four sintered iron stator cups and the four soft iron rotor discs have 50 teeth. The bifilar wound ring coils are designed for a supply of 5 V and 1 A per phase. Connecting leads are soldered to the coils and relieved from strain.

Precision ball bearings are used, permitting a maximum wobble of the spindle of 20  $\mu\text{m}$ .

There are versions with single spindle (see Fig. 1) and with double spindle (see Fig. 2).

TECHNICAL DATA

Outlines

a. versions with 2 x 3 leads

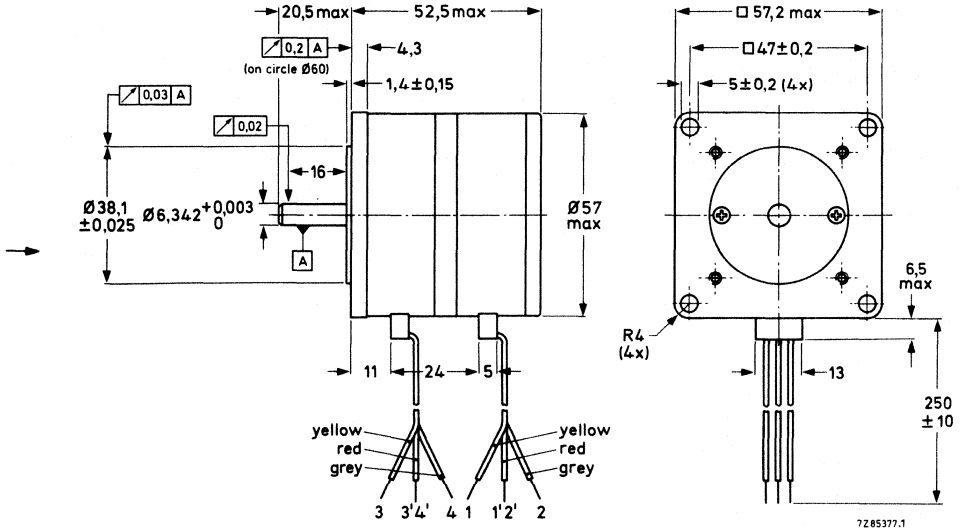

Fig. 1.

b. versions with 2 x 4 leads.

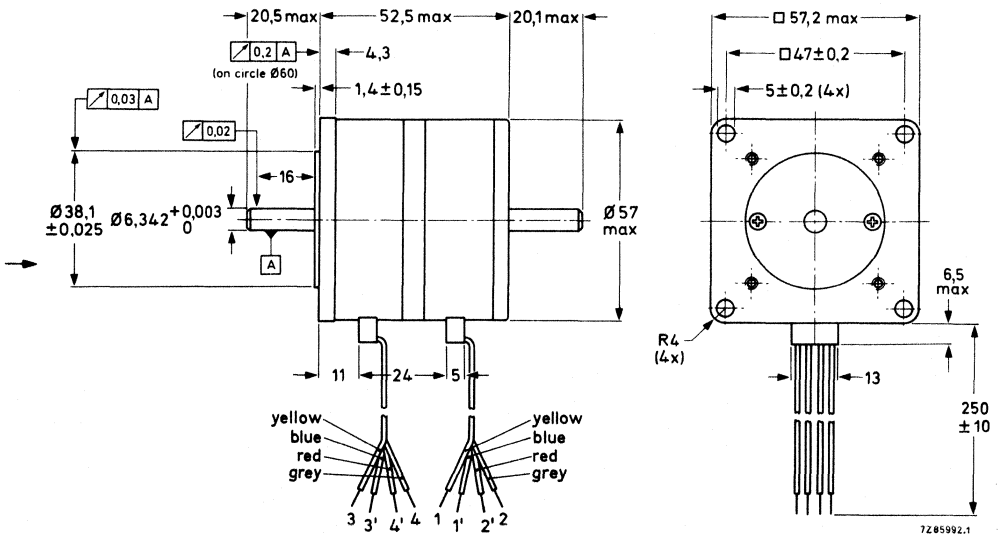

Fig. 2.

catalogue number

9904 115 23 . . . followed by:

	101	102	111	112	
spindle leads	single 2 x 3	single 2 x 4	double 2 x 3	double 2 x 4	
Drive	unipolar		bipolar		
Drive unit	9904 131 03006*		9904 131 03007**		
Power supply	12		40		V
$R_V$	3,9		—		$\Omega$
Power consumption of motor only	8		4		W
Maximum working torque	340		320		mNm
Torque derating	0,4		0,2		%/K
Holding torque			450		mNm
Maximum pull-in rate	300		600		Hz
Maximum pull-out rate	400(4000)		850(7000)		Hz
Resistance per phase (at 20 °C)			4		$\Omega$
Inductance per phase			5		mH
Current per phase	1000		500		mA
Thermal resistance, coil — ambient					K/W
Permissible ambient temperature range			-20 to + 50		°C
Permissible storage temperature range			-40 to + 100		°C
Permissible motor temperature			130		°C
Insulation			CEE, class III		
Insulation resistance at 500 V d.c.			$\geq 2$		M $\Omega$
Step angle			1,8		degrees
Step angle tolerance (non-cumulative)			$\pm 5$		%
Number of steps per resolution			200		
Direction of rotation			reversible		
Rotor inertia			145		gcm <sup>2</sup>
Bearings			ball		
Mass			600		g
Maximum radial force			50		N
Maximum axial force					
continuously			20		N
once, for pressing a pulley or pinion					
without support of spindle			100		N

\* Unipolar drive is permissible for all versions. The drive circuit must be modified for 1 A (sample type number 8204 045 20055).

\*\* Bipolar drive is only possible for versions 9904 115 23102 and 9904 115 23112 which have eight leads. The coils have to be connected in series, see Fig. 9.

Motor 9904 115 23 . . . with drive unit 9904 131 03006 in unipolar operation

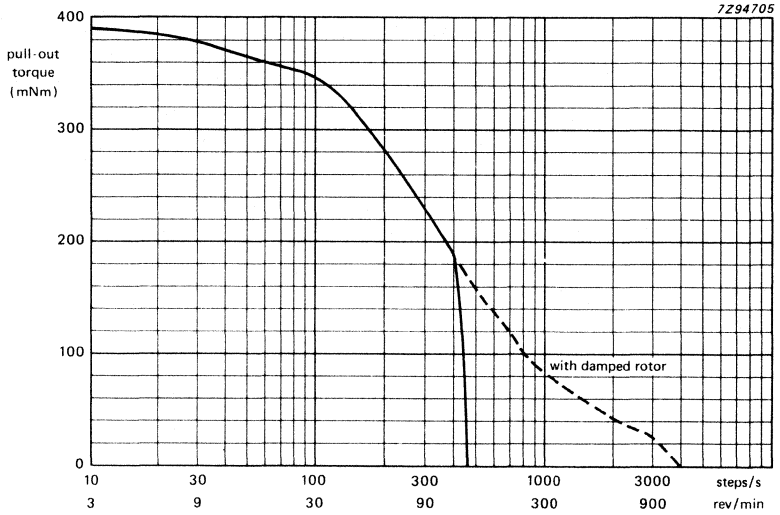

Fig. 3 Torque versus stepping rate, measured at room temperature.

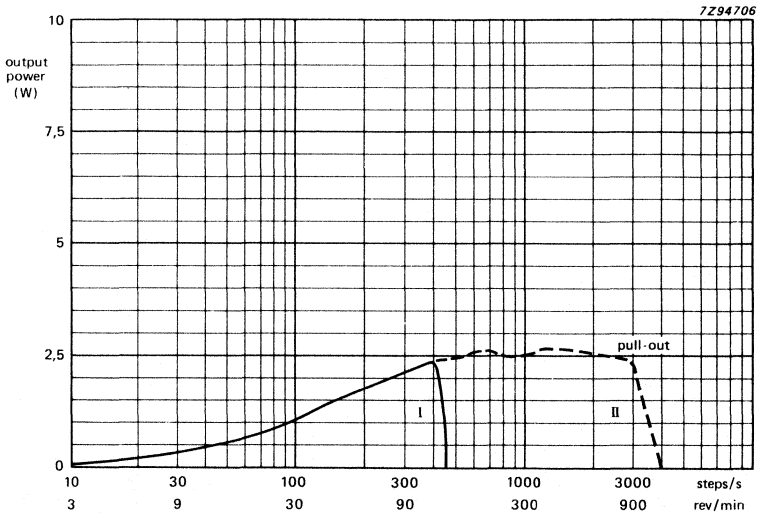

Fig. 4 Output power versus stepping rate, measured at room temperature.



Motor 9904 115 23 . . . with drive unit 9904 131 03007 in bipolar operation

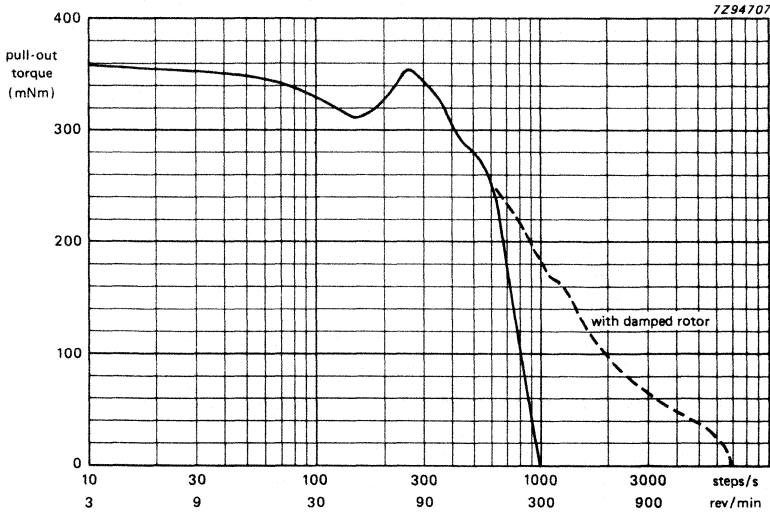

Fig. 5 Torque versus stepping rate, measured at room temperature.

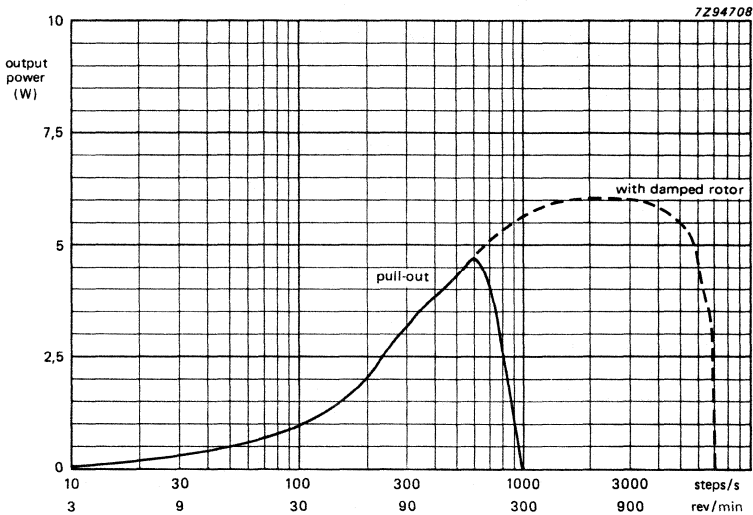
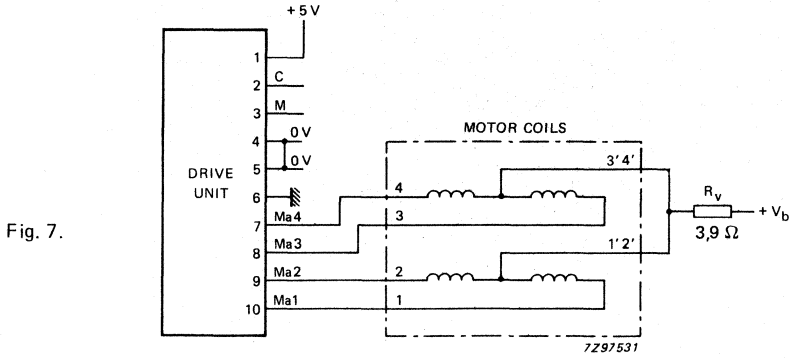
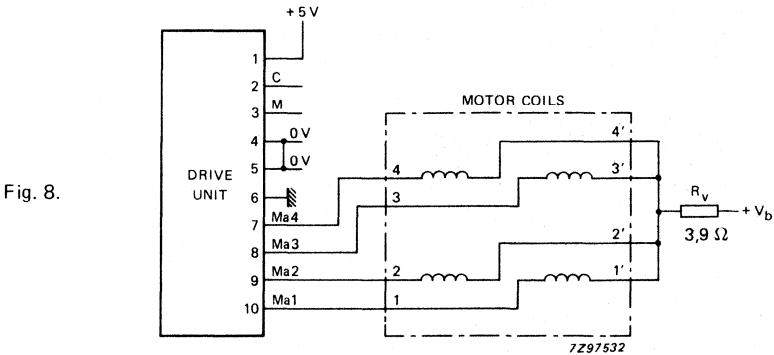

Fig. 6 Output power versus stepping rate, measured at room temperature.

Motors with 6 leads and electronic drive unit 9904 131 03006 in unipolar operation



• Motors with 8 leads and electronic drive unit 9904 131 03006 in unipolar operation



• Motors with 8 leads and electronic drive unit 9904 131 03007 in bipolar operation

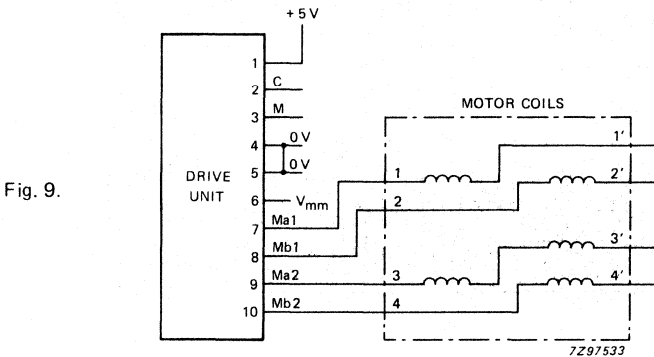

**ASSOCIATED ELECTRONICS**



## INTEGRATED CIRCUIT

for driving 4-phase unipolar stepping motors

### APPLICATION

The SAA1027 transforms an input pulse sequence into a suitable form for driving the following motors:

- |                                 |                               |
|---------------------------------|-------------------------------|
| – 9904 112 06001 (ID 06-series) | 9904 112 32001 (ID 32-series) |
| – 9904 112 27001 (ID 27-series) | 9904 112 33004 (ID 33-series) |
| – 9904 112 28001 (ID 28-series) | 9904 112 34004 (ID 34-series) |
| – 9904 112 31001 (ID 31-series) | 9904 112 35014 (ID 35-series) |
| – 9904 112 31004 (ID 31-series) | 9904 112 35016 (ID 35-series) |
| – 9904 112 31006 (ID 31-series) | 9904 112 36014 (ID 36-series) |

For detailed information on the SAA1027 see Data Handbook "Linear LSI, Supplement to IC11N"

### DESCRIPTION

The circuit comprises three input stages, a logic stage and four output stages.

The inputs are:

- C – a count input that receives the order for the rotor to step
- M – a mode input that determines the direction of rotation by setting the output pulse sequence
- R – a reset input that can be used to set the logic counter to "zero" before the trigger pulses are applied.

All three inputs are compatible with high noise immunity logic to ensure proper operation, even in noisy environments.

The four output stages can each supply 350 mA. Integrated diodes protect the outputs against transient spikes caused by switching the motor coils.

### MECHANICAL DATA

The package outline is 16-lead dual in-line; plastic (SOT-38A).

## SOLDERING

### 1. By hand

Apply the soldering iron below the seating plane (or not more than 2 mm above it) If its temperature is below 300 °C it must not be in contact for more than 10 seconds; if between 300 °C and 400 °C, for not more than 5 seconds.

### 2. By dip or wave

The maximum permissible temperature of the solder is 260 °C; solder at this temperature must not be in contact with the joint for more than 5 seconds. The total contact time of successive solder waves must not exceed 5 seconds.

The device may be mounted up to the seating plane, but the temperature of the plastic body must not exceed the specified storage maximum. If the printed-circuit board has been pre-heated, forced cooling may be necessary immediately after soldering to keep the temperature within the permissible limit.

### 3. Repairing soldered joints

The same precautions and limits apply as in (1) above.

## CONNECTIONS

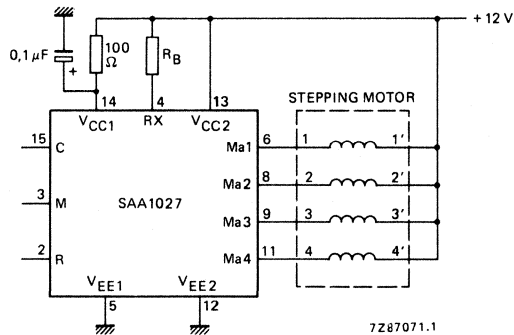

Fig. 1.

motor	R <sub>B</sub>	I <sub>system</sub> (12 V)
9904 112 06001	180 Ω, 0,67 W	500 mA
9904 112 27001	150 Ω, 1,15 W	600 mA
9904 112 28001	150 Ω, 1,15 W	600 mA
9904 112 31001	180 Ω, 0,67 W	400 mA
9904 112 31004	180 Ω, 0,67 W	400 mA
9904 112 31006	180 Ω, 0,67 W	400 mA
9904 112 32001	270 Ω, 0,33 W	300 mA
9904 112 33004	150 Ω, 0,67 W	600 mA
9904 112 34004	150 Ω, 0,67 W	600 mA
9904 112 35014	180 Ω, 0,67 W	600 mA
9904 112 35016	180 Ω, 0,67 W	600 mA
9904 112 36014	180 Ω, 0,67 W	600 mA

**ELECTRICAL DATA****Input data**

Direction of rotation (pin 3, mode input M)	max.	18 V
$V_{IH}$ , HIGH (counter-clockwise)	min.	7,5 V
$V_{IL}$ , LOW (clockwise)	max.	4,5 V
$I_{IH}$ at $V_{IH}$	typ.	1 $\mu$ A
$-I_{IL}$ at $V_{IL}$	typ.	30 $\mu$ A
Stepping (pin 15, count input C)	max.	18 V
$V_{IH}$ , HIGH	min.	7,5 V
$V_{IL}$ , LOW	max.	4,5 V
$I_{IH}$ at $V_{IH}$	typ.	1 $\mu$ A
$-I_{IL}$ at $V_{IL}$	typ.	30 $\mu$ A
Triggering occurs when C goes from LOW to HIGH.		
Set control (pin 2, reset input R)	max.	18 V
$V_{IH}$ , HIGH	min.	7,5 V
$V_{IL}$ , LOW	max.	4,5 V
$I_{IH}$ at $V_{IH}$	typ.	1 $\mu$ A
$-I_{IL}$ at $V_{IL}$	typ.	30 $\mu$ A

Note: When C is HIGH and R is LOW the outputs are:  $Q_1 = \text{LOW}$ ,  $Q_2 = \text{HIGH}$ ,  $Q_3 = \text{LOW}$ ,  $Q_4 = \text{HIGH}$ .

**Remarks**

Four integrated diodes dissipate the energy stored in the motor coils when the outputs Q are being switched.

- The common line of these clamping diodes (pin 13) must therefore have the shortest possible connection to the common line of the motor windings. Due to higher dissipation the temperature rise of the IC increases with the stepping rate of the motor. This reduces the maximum permissible ambient temperature in which the IC can operate. To counteract this, external diodes, such as BAX12, across the motor windings are recommended (see Fig. 3).
- If the R input is not used it should be connected to the supply.
- When both the IC and the motor are connected to the same supply, a simple RC network (see Figs 2 and 3) must be used in the logic supply line to prevent the logic sequence from being disturbed by transient spikes caused by the motor coils being switched. The  $R_B$  value varies per motor type. The capacitor should be connected as close as possible to pin 14.

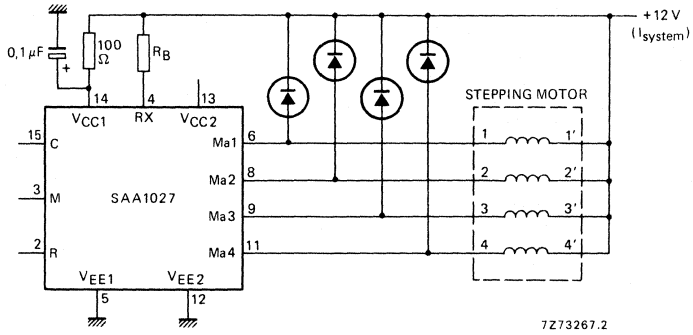

Fig. 2.

Maximum permissible ambient operating temperatures (in °C)

motor	without external diodes*	with external diodes
9904 112 06001	65	80
9904 112 27001	55	70
9904 112 28001	65	70
9904 112 31001	70	90
9904 112 31004	70	90
9904 112 31006	70	90
9904 112 32001	80	90
9904 112 33004	55	70
9904 112 34004	65	70
9904 112 35014	65	70
9904 112 35016	65	70
9904 112 36014	70	90

Minimum permissible ambient operating temperature: -20 °C.

Max. storage temperature: +125 °C

Min. storage temperature: -40 °C.

\* 13 is connected to +12 V.



## ELECTRONIC DRIVE UNIT

### 4-phase unipolar

#### DESCRIPTION

The unit has been designed as a 4-phase motor drive that needs a clock or microprocessor pulse to determining the stepping rate. N74LS74N and N74LS86N provide the logic translator function.

The supply voltage is 5 V; the drive voltage for the motor coils can be chosen in such a way that maximum output of the stepping motor is obtained.

The unit is fitted with connection tags that allow the alternative of direct soldered connections instead of the connector with which it is supplied.

#### TECHNICAL DATA

Mass 30 g

#### Ambient temperature range

operating 0 to +70 °C  
storage -40 to +70 °C

#### Power supply

$V_b$  5 V  $\pm$  5%  
 $I_b$  max (at 5 V) 45 mA

#### Direction of rotation ( $V_m$ )

$V_m = '1'$  (CW)  $V_b \geq V_m > 2,0$  V  
 $V_m = '0'$  (CCW)  $0 \text{ V} \leq V_m < 0,8$  V  
 $I_m$  max ( $V_m = '1'$ ) 0,2 mA  
 $-I_m$  max ( $V_m = '0'$ ) 0,8 mA  
 $-I_m$  limiting value 30 mA  
 $V_m$  limiting value 7 V

#### Switching pulses ( $V_c$ )

$V_c = '1'$   $V_b \geq V_c > 2,0$  V  
 $V_c = '0'$   $0 \text{ V} \leq V_c < 0,8$  V  
 $I_c$  max ( $V_c = '1'$ ) 0,2 mA  
 $-I_c$  max ( $V_c = '0'$ ) 0,8 mA  
 $-I_c$  limiting value 30 mA  
Pulse frequency 25 kHz  
Min. pulse width 100 ns  
 $V_c$  limiting value 7 V

#### Output

Permissible voltage, at each output 100 V  
Permissible current, per output 600 mA  
Saturation voltage  $< 1,3$  V

The inputs are:

- C – a count input that receives the order for the rotor to step
- M – a mode input that determines the direction of rotation by setting the output pulse sequence

Main dimensions

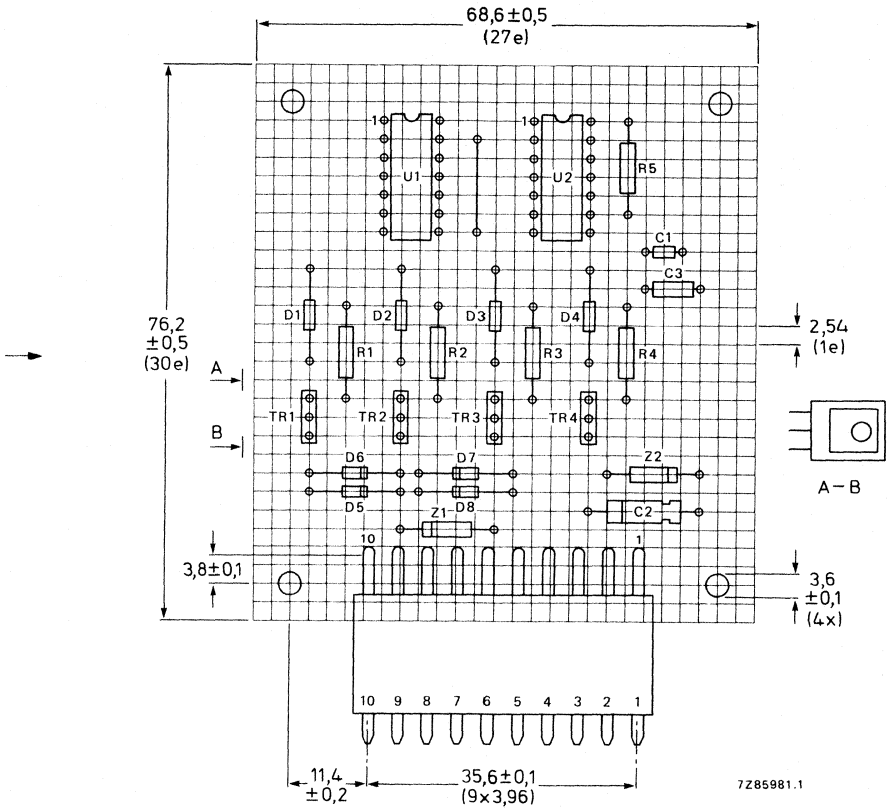

7Z85981.1

Fig. 1 Board thickness: 1,6 mm; Cu thickness: 35 μm; tracks covered with solderresist, class 1.



Parts list to Fig. 2

component	description	value	tolerance
R1 – R5	metal film resistor, SFR25	1 k $\Omega$	5%
C1	capacitor	1 nF, 100 V	-20/+ 50%
C2	electrolytic capacitor	100 $\mu$ F, 10 V	
C3	capacitor	100 nF	$\pm$ 10%
TR1 – TR4	transistor	BDX44	
D1 – D4	diode	BAW62	
D5 – D8	diode	BAX12	
Z1	voltage regulator diode	BZX87–C75	
Z2	voltage regulator diode	BZX79–C5V6	
U1	integrated circuit	N74LS74N	
U2	integrated circuit	N74LS86N	

CONNECTING DIAGRAM

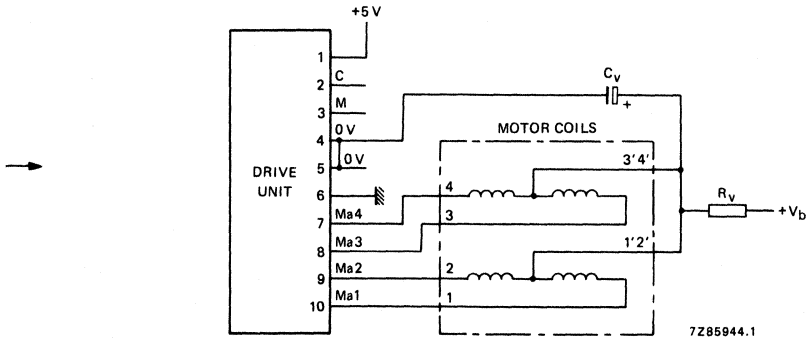

Fig. 3.

## ELECTRONIC DRIVE UNIT

### 2-phase bipolar

#### DESCRIPTION

This unit has been designed as a straightforward 2-phase bipolar motor drive that only needs a clock or microprocessor pulse to determine the stepping rate. N74LS74N and N74LS86N ICs provide the logic translator function.

Output stages and current sensing control is incorporated in two PBL3717B\* ICs. Output current for each phase can be set by R3 and R8. Maximum output current for each phase is 600 mA at 45 V and 55 °C ambient temperature. Both ICs have heatsinks for extra security.

The unit is fitted with connection tags that allow the alternative of direct soldered connections instead of the connector with which it is supplied.

#### TECHNICAL DATA

Mass 50 g.

#### Ambient temperature range

operating 0 to 70 °C  
storage -40 to 70 °C

#### Power supply

$V_b$  5 V  $\pm$  5%  
 $I_b$  max (at 5 V) 75 mA

#### Direction of rotation

$V_m = '1'$  (CW)  $V_b \geq V_m > 2,0$  V  
 $V_m = '0'$  (CCW)  $0$  V  $\leq V_m < 0,8$  V  
 $I_m$  max ( $V_m = '1'$ ) 0,2 mA  
 $-I_m$  max ( $V_m = '0'$ ) 0,8 mA  
 $-I_m$  limiting value 30 mA  
 $V_m$  limiting value 7 V

#### Switching pulses ( $V_c$ )

$V_c = '1'$   $V_b \geq V_c > 2,0$  V  
 $V_c = '0'$   $0$  V  $\leq V_c < 0,8$  V  
 $I_c$  max ( $V_c = '1'$ ) 0,2 mA  
 $-I_c$  max ( $V_c = '0'$ ) 0,8 mA  
 $-I_c$  limiting value 30 mA  
Pulse frequency 25 kHz  
Min. pulse width 100 ns  
 $V_c$  limiting value 7 V

#### Output

$V_{mm}$ , limiting value 45 V  
 $V_{mm}$ , recommended value 10 to 40 V  
 $I_{max}$  ( $T_{amb} = 70$  °C) 2 x 500 mA  
 $I_{max}$  ( $T_{amb} = 55$  °C) 2 x 600 mA  
 $V_{sat}$  (total at  $I_m = 500$  mA) 4 V

The inputs are:

- C — a count input that receives the order for the rotor to step
- M — a mode input that determines the direction of rotation by setting the output pulse sequence
- R — a reset input that can be used to set the logic counter to "zero" before the trigger pulses are applied.

\* Types of RIFA, Sweden.

Main dimensions

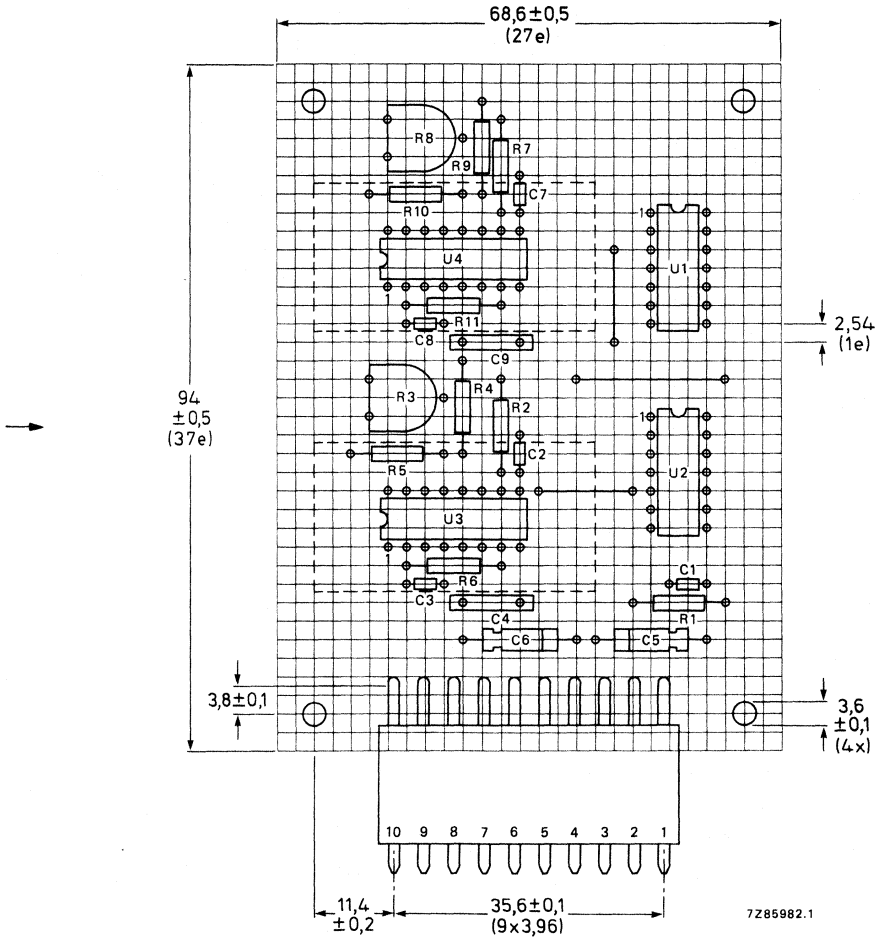

Fig. 1 Board thickness: 1,6 mm; Cu thickness: 35 µm; tracks cover with solderresist, class 1.

**CIRCUIT DIAGRAM**  
(parts list next page).

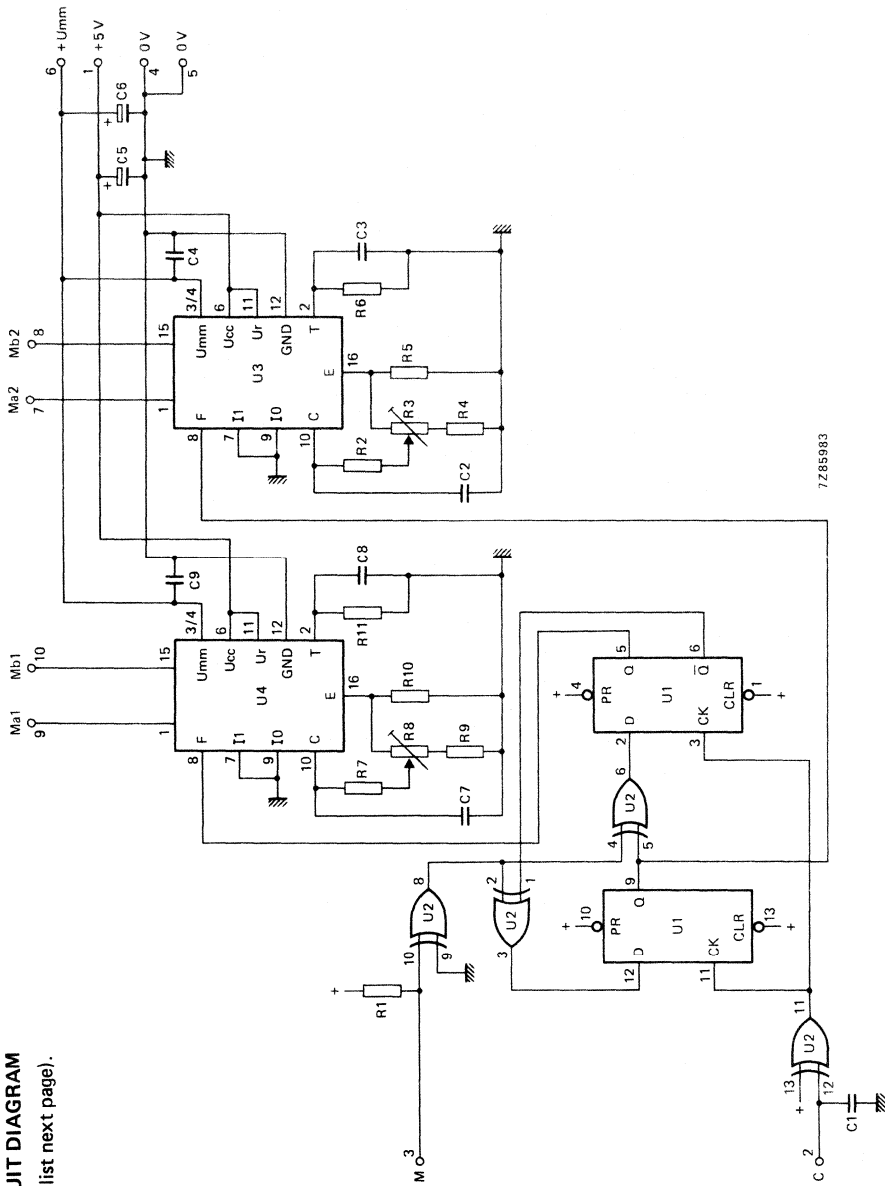

Fig. 2 For connection diagrams see Fig. 3.

**CIRCUIT DIAGRAM**

Parts list to Fig. 2.

components	description	value	tolerance
U1	integrated circuit N74LS74N		
U2	integrated circuit N74LS86N		
U3, U4	integrated circuit PBL3717B		
R1, R2, R7	metal film resistor	1 k $\Omega$ , 1/8 W	5%
R3, R8	preset potentiometer	100 $\Omega$ , 1/8 W	5%
R4, R9	metal film resistor	82 $\Omega$ , 1/8 W	5%
R5, R10	metal film resistor	1,2 $\Omega$ , 1/4 W	5%
R6, R11	metal film resistor	56 k $\Omega$ , 1/8 W	5%
C1, C2, C3, C7, C8	ceramic capacitor	820 pF	
C4, C9	polyester capacitor	15 nF	
C5	electrolytic capacitor	47 $\mu$ F, 25 V	
C6	electrolytic capacitor	10 $\mu$ F, 63 V	

**CONNECTING DIAGRAM**

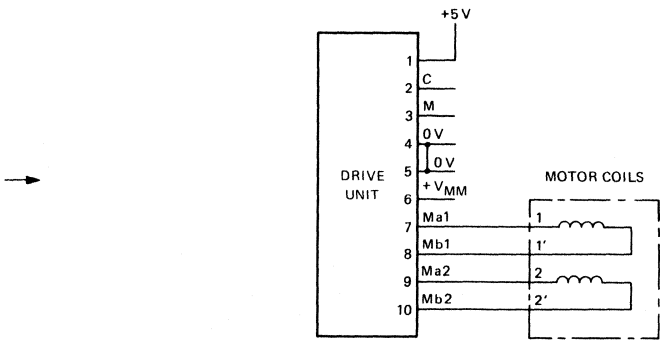

7285945.1



## ELECTRONIC DRIVE UNIT

### 4-phase bipolar

#### DESCRIPTION

This unit has been designed as a straightforward 2-phase bipolar constant current drive that only needs a clock or microprocessor pulse to determine the stepping rate. N74LS74N and N74LS86N ICs provide the logic translator function.

Output stages and current sensing control is incorporated in four PBL3717B\* ICs. Output current for each phase can be set individually by R2, R7, R12 and R17. Maximum output current for each phase is 600 mA at 45 V and 55 °C ambient temperature. The four ICs have heatsinks for extra security.

The unit is fitted with connection tags that allow the alternative of direct soldered connections instead of the connector with which it is supplied.

#### TECHNICAL DATA

Mass            50 g

##### Ambient temperature range

operating            0 to 70 °C  
storage                -40 to 70 °C

##### Power supply

$V_b$                     5 V  $\pm$  5%  
 $I_b$  max (at 5 V)    130 mA

##### Direction of rotation

$V_m = '1'$  (CW)         $V_b \geq V_m > 2,0$  V  
 $V_m = '0'$  (CCW)     $0$  V  $\leq V_m < 0,8$  V  
 $I_m$  max ( $V_m = '1'$ )    0,2 mA  
 $-I_m$  max ( $V_m = '0'$ )    0,8 mA  
 $-I_m$  limiting value    30 mA  
 $V_m$  limiting value     7 V

##### Switching pulses ( $V_c$ )

$V_c = '1'$                      $V_b \geq V_c > 2,0$  V  
 $V_c = '0'$                      $0$  V  $\leq V_c < 0,8$  V  
 $I_c$  max ( $V_c = '1'$ )        0,2 mA  
 $-I_c$  max ( $V_c = '0'$ )        0,8 mA  
 $-I_c$  limiting value        30 mA  
Pulse frequency         25 kHz  
Min. pulse width        100 ns  
 $V_c$  limiting value        7 V

##### Output

$V_{MM}$ , limiting value     45 V  
 $V_{MM}$ , recommended value 10 to 40 V  
 $I_{max}$  ( $T_{amb} = 70$  °C)    4 x 500 mA  
 $I_{max}$  ( $T_{amb} = 55$  °C)    4 x 600 mA  
 $V_{sat}$  (total at  $I_m = 500$  mA) 4 V

The inputs are:

- C — a count input that receives the order for the rotor to step.
- M — a mode input that determines the direction of rotation by setting the output pulse sequence

\* Type of RIFA, Sweden.

Main dimensions

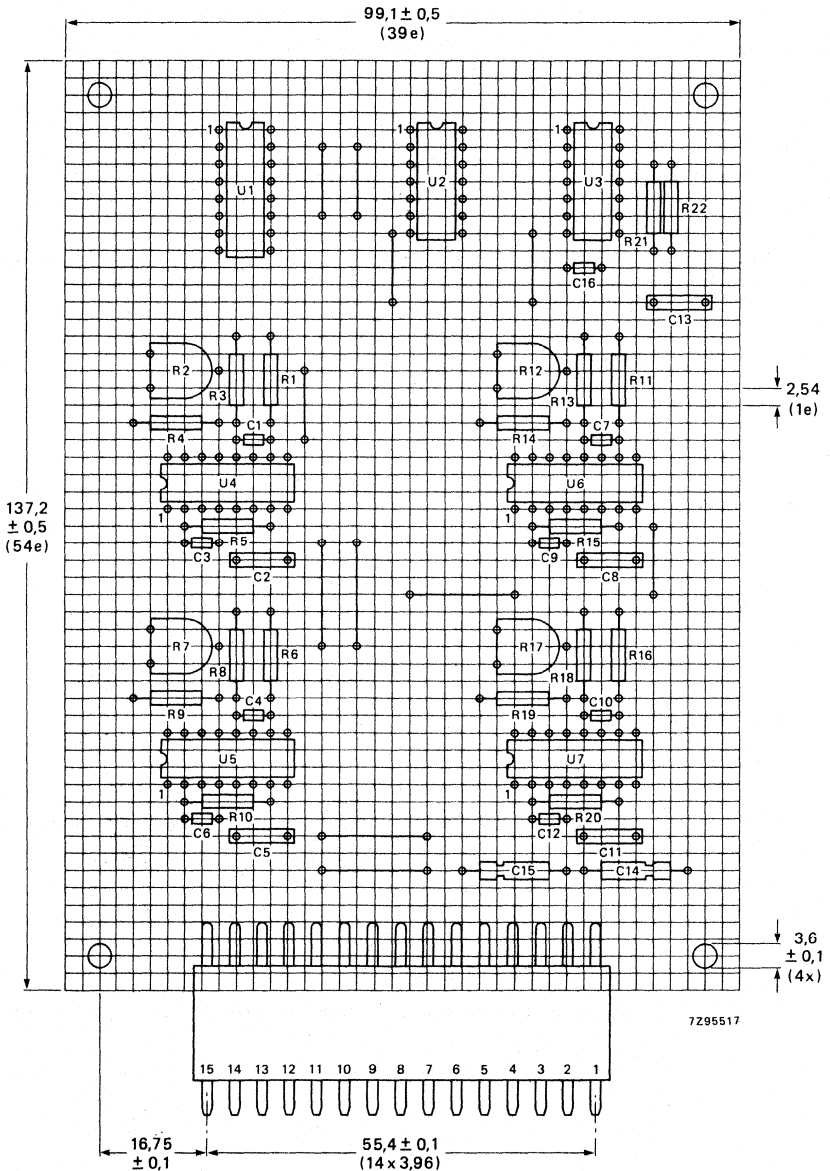

Fig. 1 Board thickness: 1,6 mm; Cu thickness: 35  $\mu$ m; tracks covered with solderesist, class 1.

**CIRCUIT DIAGRAM**  
(parts list next page).

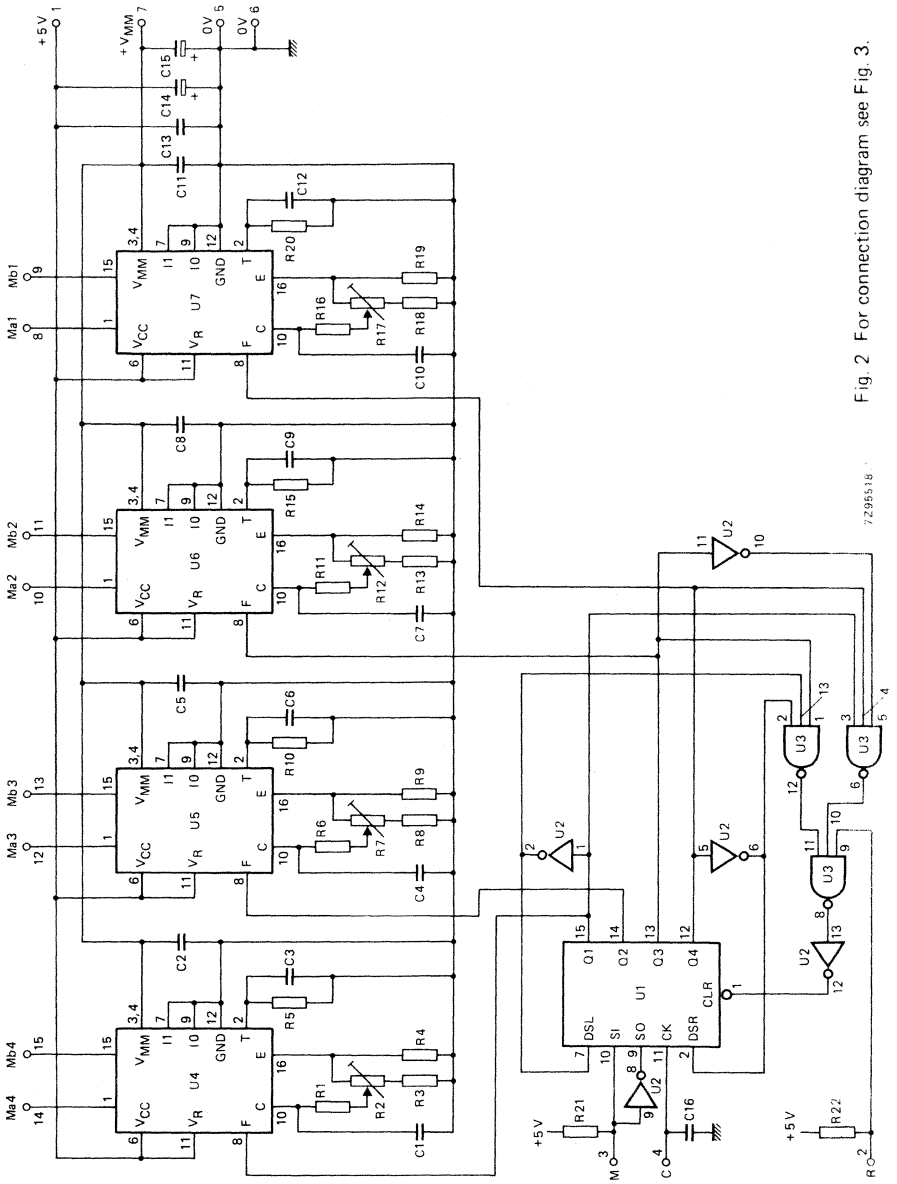

Fig. 2 For connection diagram see Fig. 3.

**CIRCUIT DIAGRAM**

Parts list to Fig. 2.

components	description	value	type
U1	integrated circuit		N74LS194AN
U2	integrated circuit		N74LS04N
U3	integrated circuit		N74LS10N
U4, U5, U6, U7	integrated circuit		PBL3717B
R1, R6, R11, R16 R21, R22	metal film resistor	1 k $\Omega$ ; 0,125 W	2322 181 13102
R3, R8, R13, R18	metal film resistor	82 $\Omega$ ; 0,125 W	2322 181 13829
R4, R9, R14, R19	metal film resistor	1,2 $\Omega$ ; 0,25 W	2322 182 13128
R5, R10, R15, R20	metal film resistor	56 k $\Omega$ ; 0,125 W	2322 181 13563
R2, R7, R12, R17	preset potentiometer	100 $\Omega$	2322 410 03351
C1, C3, C4, C6, C7, C9, C10, C12, C16	ceramic capacitor	820 pF	2222 630 09821
C2, C5, C8, C11	polyester capacitor	15 nF	2222 366 51153
C13	polyester capacitor	100 nF	2222 366 21104
C14	electrolytic capacitor	47 $\mu$ F; 25 V	2222 030 26479
C15	electrolytic capacitor	10 $\mu$ F; 63 V	2222 030 28109

**CONNECTION DIAGRAM**

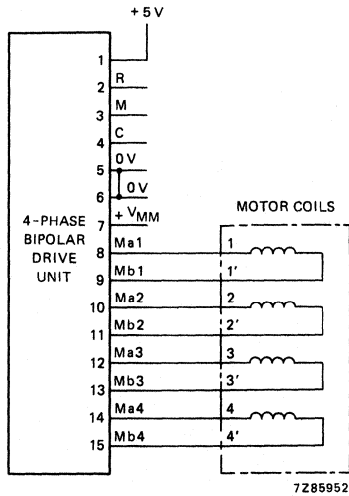

Fig. 3.

## INDEX OF CATALOGUE NUMBERS

catalogue no.	page	catalogue no.	page
9904 112 06001	33	9904 115 15101	115
06101	33	15201	119
27001	37	15401	123
27101	37	23101	127
27201	41	23102	127
28001	45	23111	127
28101	45	23112	127
28201	49		
29201	52	9904 131 03006	139
30201	55	03007	143
31001	59	03008	147
31004	63	SAA1027	135
31006	67		
31101	59		
31104	63		
31106	67		
31206	71		
32001	75		
32101	75		
32204	79		
33004	83		
33104	83		
33105	87		
34004	91		
34104	91		
35014	95		
35016	99		
35114	95		
35116	99		
35214	103		
35216	107		
36014	111		
36114	111		





**Argentina:** PHILIPS ARGENTINA S.A., Div. Elcoma, Vedia 3892, 1430 BUENOS AIRES, Tel. 541-7141/7242/7343/7444/7545.  
**Australia:** PHILIPS INDUSTRIES HOLDINGS LTD., Elcoma Division, 67 Mars Road, LANE COVE, 2066, N.S.W., Tel. 427 0888.  
**Austria:** ÖSTERREICHISCHE PHILIPS BAUELEMENTE INDUSTRIE G.m.b.H., Triester Str. 64, A-1101 WIEN, Tel. 62 91 11-0.  
**Belgium:** N.V. PHILIPS & MBLE ASSOCIATED, 9 rue du Pavillon, B-1030 BRUXELLES, Tel. (02) 242 7400.  
**Brazil:** IBRAPE, Caixa Postal 7383, Av. Brigadeiro Faria Lima, 1735 SAO PAULO, SP, Tel. (011) 211-2600.  
**Canada:** PHILIPS ELECTRONICS LTD., 601 Milner Ave., SCARBOROUGH, Ontario, M1B 1M8, Tel. 292-5161.  
**Chile:** PHILIPS CHILENA S.A., Av. Santa Maria 0760, SANTIAGO, Tel. 39-4001.  
**Colombia:** IND. PHILIPS DE COLOMBIA S.A., c/o IPRELENZO LTD., Cra. 21, No. 56-17, BOGOTA, D.E., Tel. 2497624.  
**Denmark:** MINIWATT A/S, Strandlodsvej 2, P.O. Box 1919, DK 2300 COPENHAGEN S, Tel. (01) 54 11 33.  
**Finland:** OY PHILIPS AB, Elcoma Division, Kaivokatu 8, SF-00100 HELSINKI 10, Tel. 172 71.  
**France:** RTC-COMPELEC, 130 Avenue Ledru Rollin, F-75540 PARIS 11, Tel. 43 38 8000.  
**Germany (Fed. Republic):** VALVO, UB Bauelemente der Philips G.m.b.H., Valvo Haus, Burchardstrasse 19, D-2 HAMBURG 1, Tel. (040) 3296-0.  
**Greece:** PHILIPS HELLENIQUE S.A., Elcoma Division, 54, Syngrou Av., ATHENS 11742, Tel. 9215311/319.  
**Hong Kong:** PHILIPS HONG KONG LTD., Elcoma Div., 15/F Philips Ind. Bldg., 24-28 Kung Yip St., KWAI CHUNG, Tel. (0)-24 51 21.  
**India:** PEICO ELECTRONICS & ELECTRICALS LTD., Elcoma Dept., Band Box Building, 254-D Dr. Annie Besant Rd., BOMBAY - 400 025, Tel. 4930311/4930590.  
**Indonesia:** P.T. PHILIPS-RALIN ELECTRONICS, Elcoma Div., Setiabudi II Building, 6th Fl., Jalan H.R. Rasuna Said (P.O. Box 223/KBY), Kuningan, JAKARTA - Selatan, Tel. 512572  
**Ireland:** PHILIPS ELECTRICAL (IRELAND) LTD., Newstead, Clonskeagh, DUBLIN 14, Tel. 693355.  
**Italy:** Britelec S.R.L., Viale Fulvio Testi 327, I-20162 MILANO, Tel. 02-6445.  
**Japan:** NIHON MICRO MOTOR, Mikamo Bldg., 2-3 chome Sakae-cho, Tachikawa-city, TOKYO, Japan 190, Tel. 0425-27,7722.  
**Korea (Republic of):** PHILIPS ELECTRONICS (KOREA) LTD., Elcoma Div., Philips House, 260-199 Itaewon-dong, Yongsan-ku, SEOUL, Tel. 794-5011.  
**Malaysia:** PHILIPS MALAYSIA SDN. BERHAD, No. 4 Persiaran Barat, Petaling Jaya P.O.B. 2163, KUALA LUMPUR, Selangor, Tel. 77 44 11.  
**Mexico:** ELECTRONICA, S.A de C.V., Carr. México-Toluca km. 62 5, TOLUCA, Edo. de México 50140, Tel. Toluca 91(721) 613-00.  
**Netherlands:** PHILIPS NEDERLAND, Marktgroep Elonco, Postbus 90050, 5600 PB EINDHOVEN, Tel. (040) 793333.  
**New Zealand:** PHILIPS NEW ZEALAND LTD., Elcoma Division, 110 Mt. Eden Road, C.P.O. Box 1041, AUCKLAND, Tel. 605-914.  
**Norway:** NORSK A/S PHILIPS, Electronica Dept., Sandstuveien 70, OSLO 6, Tel. 6802 00.  
**Peru:** CADESA, Av. Jiron Nazca 704, Apartado No. 5612, LIMA II, Peru, Tel. 319253.  
**Philippines:** PHILIPS INDUSTRIAL DEV. INC., 2246 Pasong Tamo, P.O. Box 911, Makati Comm. Centre, MAKATI-RIZAL 3116, Tel. 86-89-51 to 59.  
**Portugal:** PHILIPS PORTUGUESA S.A.R.L., Av. Eng. Duarte Pacheco 6, 1009 LISBOA Codex, Tel. 683121.  
**Singapore:** PHILIPS PROJECT DEV. (Singapore) PTE LTD., Elcoma Div., Lorong 1, Toa Payoh, SINGAPORE 1231, Tel. 25 38 811.  
**South Africa:** EDAC (PTY.) LTD., 3rd Floor Rainer House, Upper Railway Rd. & Ove St., New Doornfontein, JOHANNESBURG 2001, Tel. 614-2362/9.  
**Spain:** MINIWATT S.A., Balmes 22, BARCELONA 7, Tel. 301 63 12.  
**Sweden:** PHILIPS KOMPLEMENTER A.B., Lidingsvägen 50, S-11584 STOCKHOLM 27, Tel. 08/7821000.  
**Switzerland:** PHILIPS A.G., Elcoma Dept., Allmendstrasse 140-142, CH-8027 ZÜRICH, Tel. 01-48822 11.  
**Taiwan:** PHILIPS TAIWAN LTD., 150 Tun Hua North Road, P.O. Box 22978 TAIPEI, Taiwan, Tel. 7120500  
**Thailand:** PHILIPS ELECTRICAL CO. OF THAILAND LTD., 283 Silom Road, P.O. Box 961, BANGKOK, Tel. 233-6330-9.  
**Turkey:** TÜRK PHILIPS TICARET A.Ş., Elcoma Department, Inonu Cad. No. 78-80, P.K.504, 80074 ISTANBUL, Tel. 4359 10.  
**United Kingdom:** Impex Electrical Ltd., Market Road, Richmond, SURREY TW9 4ND, Tel. 01-876 1047.  
**United States:** North American Philips Controls Corp., Cheshire Industrial Park, Cheshire, Conn. 06410, Tel. (203) 272-0301.  
**Uruguay:** LUZINDLECTRON S.A., Avda Uruguay 1287, P.O. Box 907, MONTEVIDEO, Tel. 91 43 21.  
**Venezuela:** IND. VENEZOLANAS PHILIPS S.A., c/o MAGNETICA S.A., Calle 6, Ed. Las Tres Jotas, App. Post. 78117, CARACAS, Tel. (02) 2393931.

**For all other countries apply to:** Philips Electronic Components and Materials Division, International Business Relations, P.O. Box 218, 5600 MD, EINDHOVEN, The Netherlands, Telex 35000 phtcnl